

CAN-AM MAVERICK X3

PHASE 5

POWERSPORTS AUDIO KIT

pg 3
Disassembly, Wire and
Amplifier Plate Installation

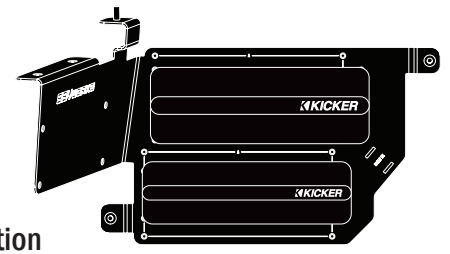

pg 11
Dash Kit Installation

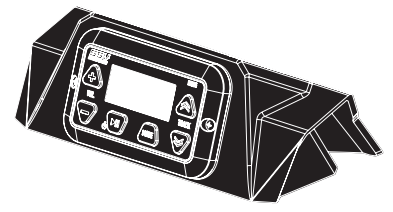

pg 15
Underseat Subwoofer
Installation

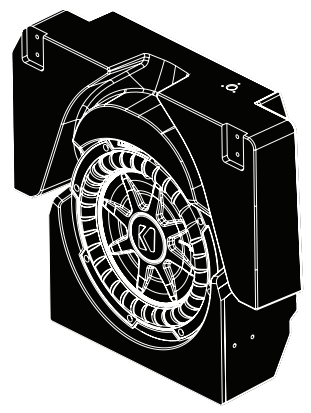

pg 19
Dash Speaker Pods
Installation

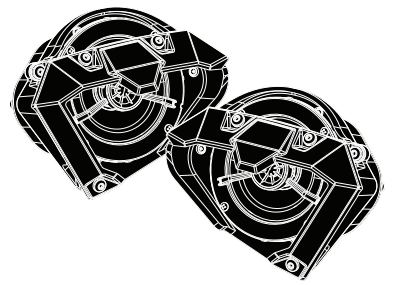

pg 23
Cage Mount Speaker Pods
Installation

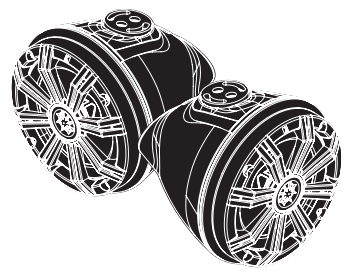



X3-5K

Can-Am Maverick X3 & X3 Max Kicker 5 Speaker Audio Kit

WARRANTY INFORMATION:

All SSV Works enclosures are covered by a limited lifetime warranty against defects in material or workmanship. All SSV Works Electronics are covered by a limited 1 year warranty against defects in material or workmanship. All SSV Works Speakers are covered by a limited 1 year warranty against defects in material or workmanship. Labor for replacement of defective components is not covered. Contact SSV Works for further warranty information.



Please read and understand these instructions completely before installation to avoid possible injury, or damage to the accessory or vehicle.

TOOLS NEEDED FOR INSTALLATION

- T30 torx
- 10mm wrench or socket
- 13mm wrench or socket
- 18 mm socket with extension
- Wire crimpers
- Panel removal tool
- #2 screw driver
- 1" Uni bit (for USB/ Aux)
- #3 screw driver

WIRE AND CABLE PARTS LIST

1. Amp Power Wire
2. Front B-H1149 Speaker Harness
3. Rear B-H1151 Speaker Expansion Harness
4. MRB3 Power & Ground Connector
5. Direct-fit Amp Plate with pre-tuned Amp(s) and MRB3 Brain
6. M6 x 1.0 Screw x 1
7. M6 Washer x 1
8. M6 Nut x 1
9. Zip Ties x
10. WP-H16PG84-6 Harness

PARTS LIST IMAGES



1. Amp Power Wire with Fuse Holder



2. Front B-H1149 Speaker Harness



3. Rear B-H1151 Speaker Expansion Harness



4. MRB3 Power & Ground Connector



5. Direct-fit Amp Plate with pre-tuned Amp(s) and MRB3 Brain



6. M6 x 1.0 Screw x 1



7. M6 Washer x 1



7. M6 Washer x 1



8. Zip Ties x 5



10. WP-H16PG84-6 Harness

PANELS AND DASH DISASSEMBLY

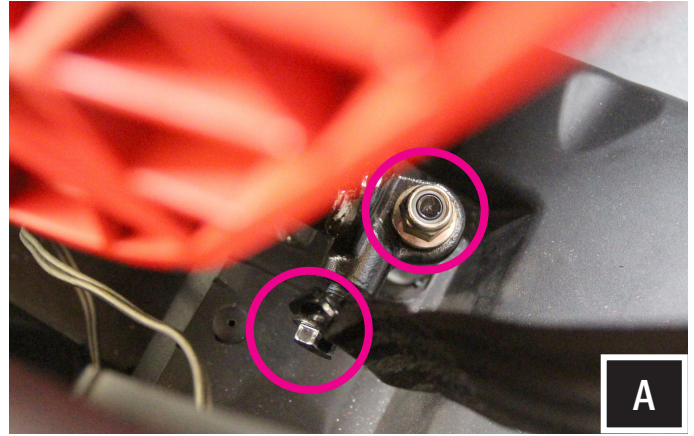

A. To remove the seat, use a 13mm socket and wrench to remove front (2) bolt and nut, and use a 18mm socket to remove (2) rear nuts and seat belt nut (repeat on other seat)

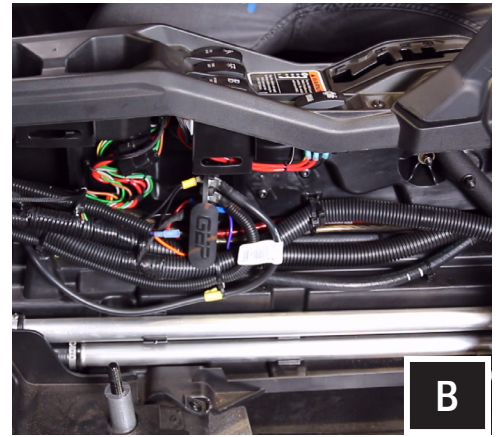
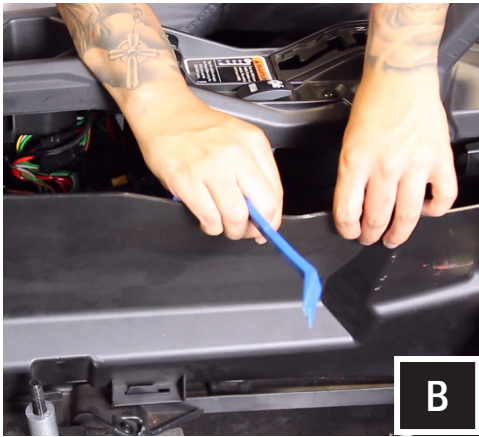

B. Carefully unsnap center dash side panels by hand or with a panel removal tool.

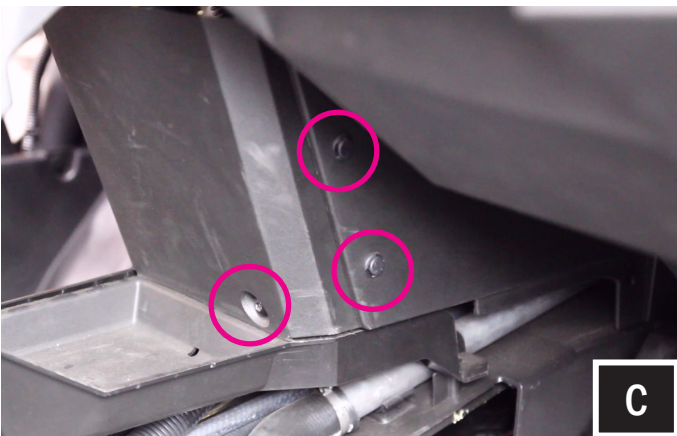

C. Unscrew (2) T30 torx located on the center console panel under the dash. Use a panel tool to remove push pins on passenger side.



D. Carefully unsnap rear cover to expose the engine compartment

PANELS AND DASH DISASSEMBLY



E. Remove gas cover on the passenger side to expose a 10mm nut. Unscrew with a wrench and T30 torx driver.

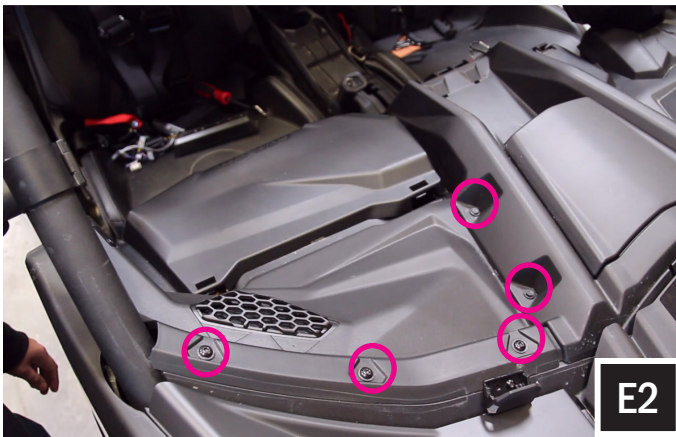

E2. Using panel removal tool unclip (2) push clips on the driver and passenger side dash covers. Unscrew the (4) T30 screws on the passenger side, and (7) T30 screws on the driver side.

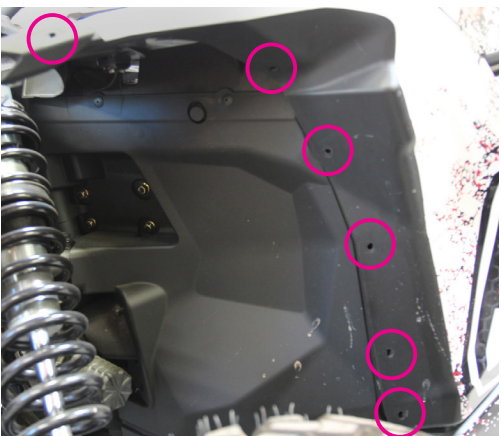

F. Remove fender well panel using a T30 driver (will need a 10mm socket for the screw near the headlight)



G. After the fender well panel is removed, remove the third fastener clip from the bottom.

RUNNING AMP POWER CABLE AND SPEAKER WIRE

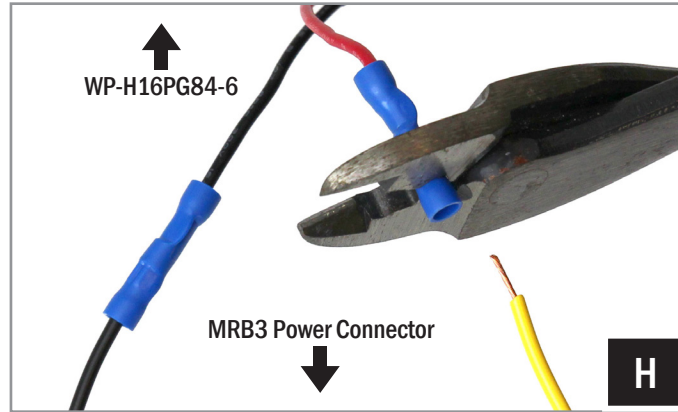

H. Connect the MRB3 Power into the WP-H16PG84-6. Using the butt splice terminals on the WP-H16PG84-6, connect black to black and red to yellow.

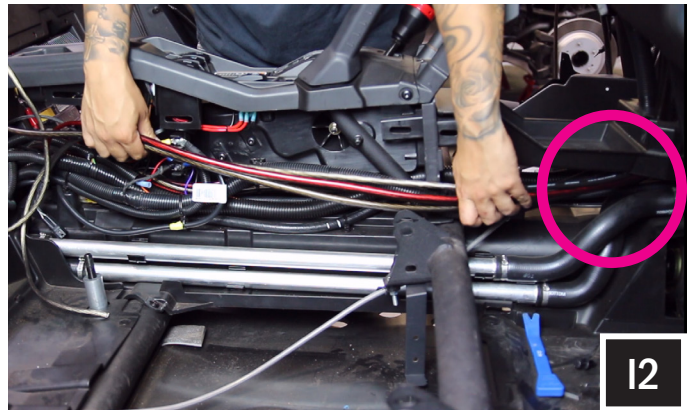
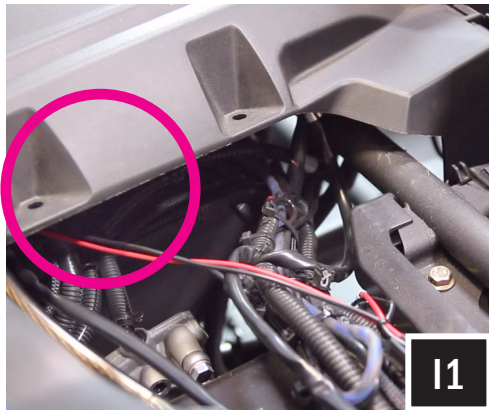

I. In this step you will be feeding all of the necessary wires from the top drivers side dash down the center dash column. Be sure to run all of the wires along side the factory cabling to avoid any moving parts. Feed both amp power wires, rear speaker expansion harness, subwoofer harness, and power/ground for MRB3 from top driver side down the center column (I1). Pull all wires through the bottom center column and across the center console with the factory wiring (I2).



J. Run rear expansion harness through rear center console cavity, following the factory cables. If you are installing a 3-speaker kit, simply zip tie the cable to a factory harness as this step is completed. If installing a 5-speaker kit, please refer to the installation of the Cage Mounted Speakers.

The connection of each cable will be address further along in the instructions.

AMP TRAY MODIFICATION WHEN USED WITH AN AFTERMARKET ROLL CAGE

1. REMOVE THIS THREADED STUD BEFORE INSTALLATION OF THE AMP TRAY. GENTLY TAP OUT THE THREADED STUD WITH A HAMMER. BE CAREFUL NOT TO BEND THE BRACKET.

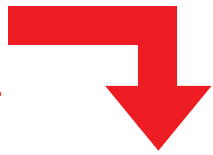

2. IF NEEDED, INCREASE THE DIAMETER OF THE HOLE TO ACCOMMODATE THE ROLL CAGE BOLT



AMP PLATE INSTALLATION

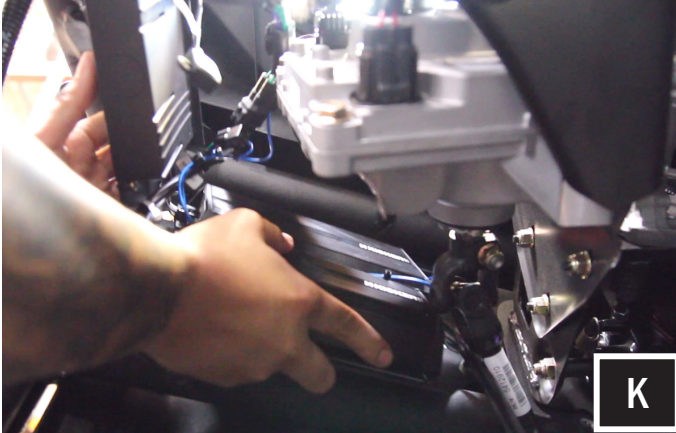

K. From underneath driver side place amp plate between the two cross bars behind the steering wheel.

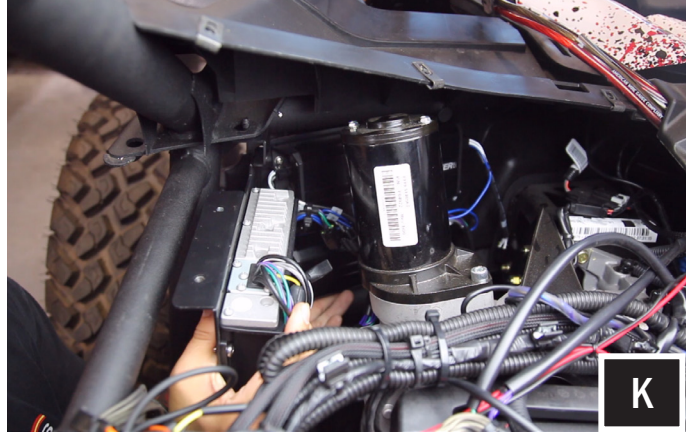

L. Make sure the threaded bolt on the amp plate goes through the factory hole located in the corner where the cage tubing connects.

* If your vehicle is equipped with an aftermarket cage, refer to page 2 for the installation of the amp tray.



M. Secure the amp tray to the vehicle using the supplied M6 nut and washer.



N. Make a pilot hole with a pick tool through the top right screw hole in the amp plate and push all the way through the vehicle panel.



O. Drill a larger hole through the pilot hole using a 1/4" drill bit. Be sure to move the amp plate out of the way before drilling.

AMP PLATE INSTALLATION

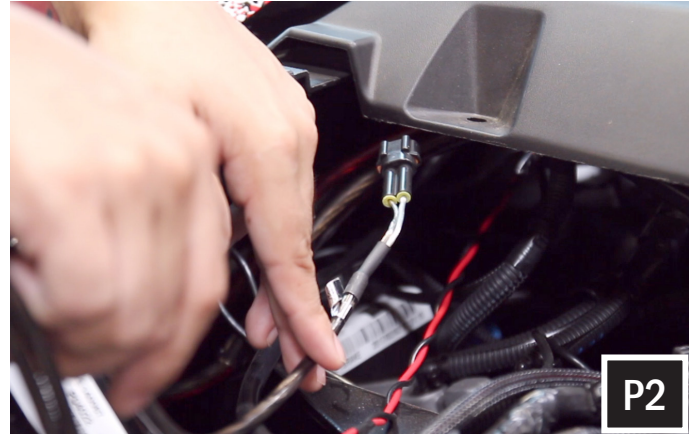

P. Route the front B-H1149 speaker harness towards the driver and passenger side of the vehicle and leave the 4 pin connector at the driver side of dash (P1). Route the passenger side speaker wire under the center dash panel all the way to the passenger side speaker location (P2).

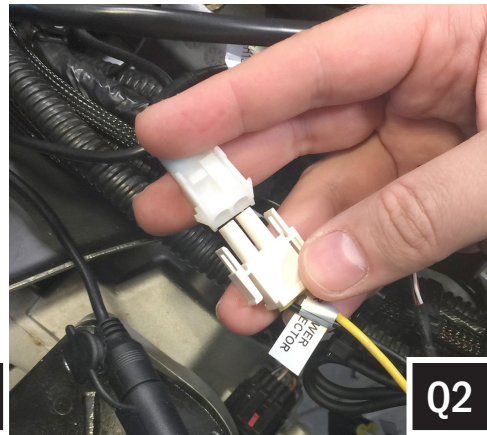
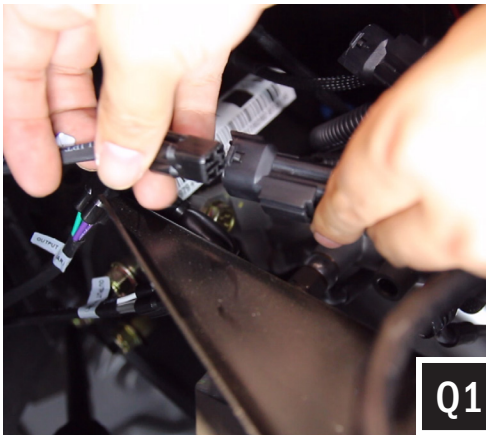

Q. Connect the B-H1149 to the front output of the 300.4 amplifier. Connect the B-H1151 to the rear output of the 300.4 amplifier. Connect the B-H1152 to the output of the 500.1 amplifier (Q1). Connect the B-H1221 MRB3 power harness to the MRB3 brain (Q2). Connect both amplifier power harnesses to each amplifier (Q3).

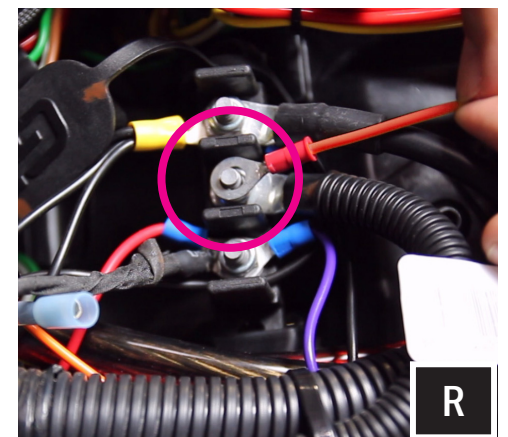
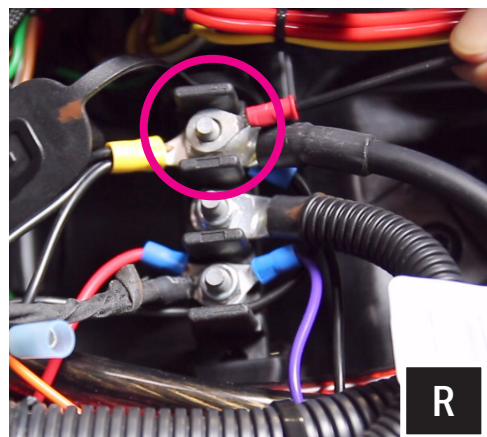
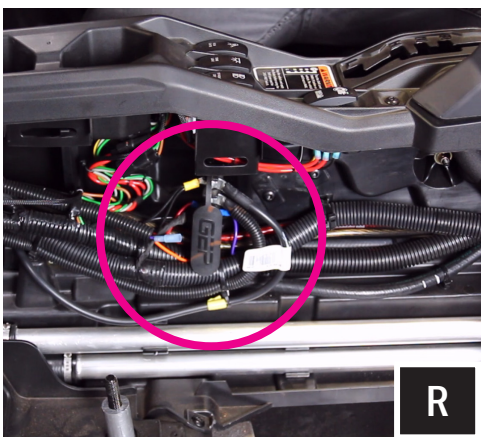

R. Connect the power and ground for the MRB3 brain on the power strip located on the passenger side of the center console. Unscrew the top post, remove the nut and install the black-ground wire terminal. Replace the nut. Unscrew the center post, remove the nut and install the red-battery power wire terminal. Replace the nut.

USB/AUX INPUT PORT INSTALLATION

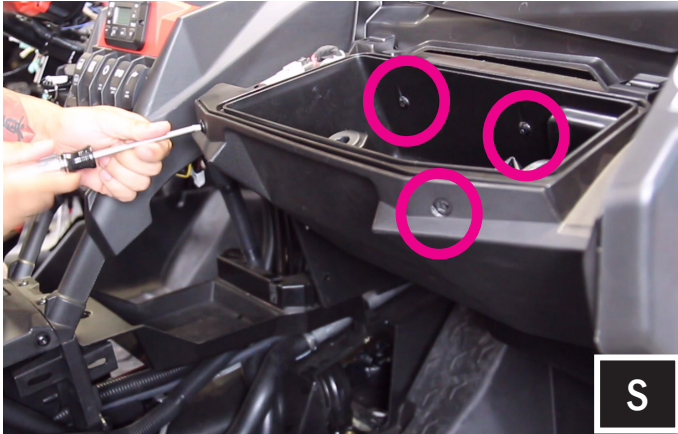

S. Remove the (4) T30 torx on the front and inside of the glove box



T. Remove push clips from underneath glove box.



U. Pull up and remove the glove box.



V. Drill a 1" hole through the left side of the glove box for wiring

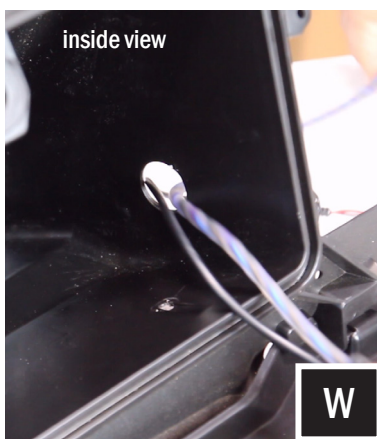

W. Unscrew and remove the plastic nut from the port. Make sure to open the fuse holder and remove the fuse so the nut will fit through it. Feed in the wires through the hole. Keep the fuse holder open and empty until it has passed through the hole.



X. Feed the plastic nut back through the wires and cables and screw back on to the port. Hand tighten only.



X3-DM3

Can-Am Commander X3

Dash Kit for MRB3

WARRANTY INFORMATION:

All SSV Works enclosures are covered by a limited lifetime warranty against defects in material or workmanship. All SSV Works Electronics are covered by a limited 1 year warranty against defects in material or workmanship. All SSV Works Speakers are covered by a limited 1 year warranty against defects in material or workmanship. Labor for replacement of defective components is not covered. Contact SSV Works for further warranty information.



Please read and understand these instructions completely before installation to avoid possible injury, or damage to the accessory or vehicle.

TOOLS NEEDED FOR INSTALLATION

- #2 Phillips Screw Driver
- 1/2" drill bit
- 1/8" drill bit
- Drill

PARTS LIST

- 1. X3-DM3 Base Plate
- 2. X3-DM3 Top Panel
- 3. #7 x 1.25 Kit Screws x4
- 4. M3 x 20mm Screws x2
- 5. M3 Washers x 2
- 6. M3 Hex Nuts x 2

PARTS LIST IMAGES



1. X3-DM3 Base Plate



2. X3-DM3 Top Panel



3. #7 x 1.25 Kit Screws x4



4. M3 x 20mm Screws x2

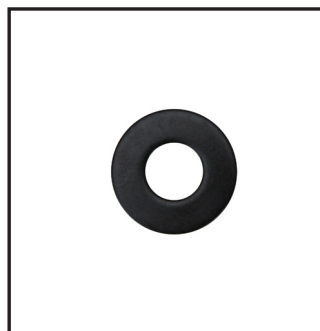

5. M3 Washers x 2



6. M3 Hex Nuts x 2

INSTALLATION NOTES

For instructions regarding the MRB3 black box, refer to the MRB3 manual.

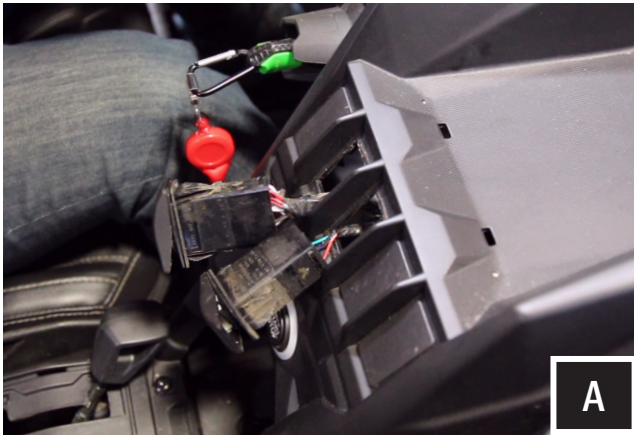

A

A. Remove the factory rocker switches.

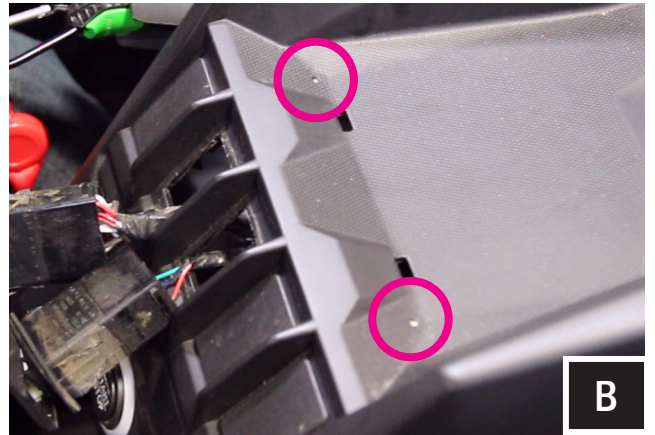

B

B. Locate the two dimples at the top of the dash. These dimples are actual screw bosses on the underside of the dash.



C

Line up base plate

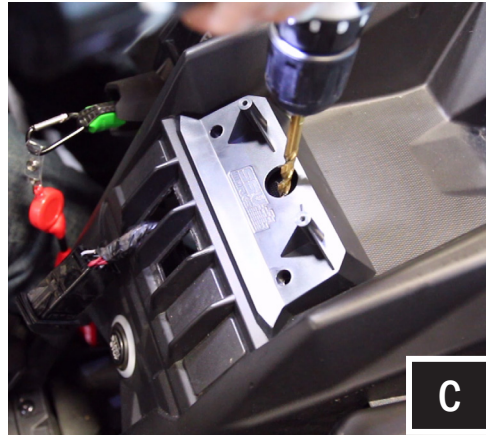

C

Drill pilot hole

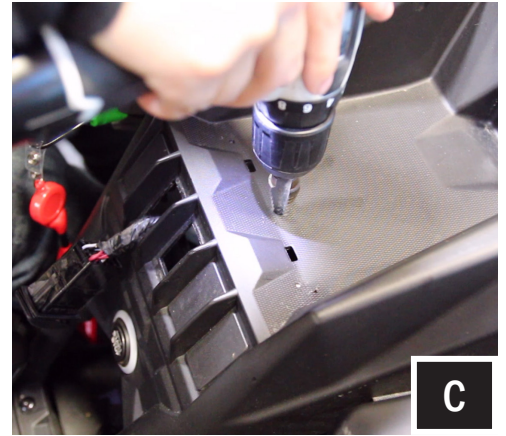

C

Drill 1/2" hole

C. Rest the X3-DM3 base plate on the dash. Line up the two outside screw holes with the dimples of the dash. Do not screw the kit in yet.

While holding the base plate down to the dash, use the center hole on the base plate to drill your 1/8" pilot hole.

Remove the base plate and open the pilot hole up using a 1/2" drill bit.



D

D. Place the base plate back on the dash lining up the outside screw holes to the dimples on the dash. Using (2) #7 Screws and a philips screw driver secure the base to the dash. Make sure the screws are driving into the dash dimples for best results.



E

E. Fasten the MRB3 Remote to the dash kit using (2) M3 screws.



F



F

F. Now that the MRB3 remote is mounted to the dash kit route the din cable through the base plate so that it drops into the dash.

Pull the din cable all the way through until the X3-DM3 Top Panel rests on the Base Plate.

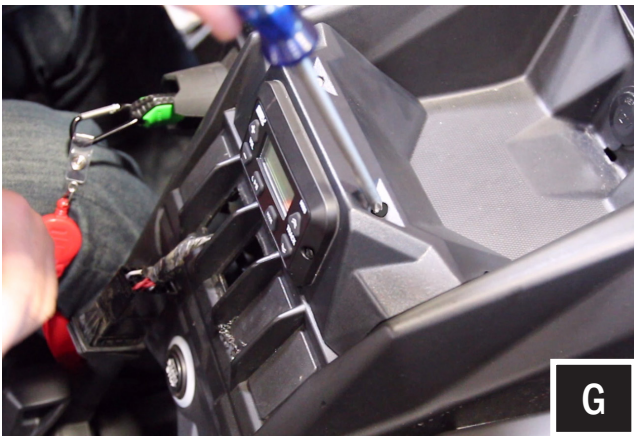

G



G

G. Using (2) #7 screws, secure the top of the Top Panel to the Base Plate.



H

H. Refer to the MRB3 manual for wiring instructions.



X3-US10K

2016+ Can-Am Maverick x3 10" Under Seat Enclosure

WARRANTY INFORMATION:

All SSV Works enclosures are covered by a limited lifetime warranty against defects in material or workmanship. All SSV Works Electronics are covered by a limited 1 year warranty against defects in material or workmanship. All SSV Works Speakers are covered by a limited 1 year warranty against defects in material or workmanship. Labor for replacement of defective components is not covered. Contact SSV Works for further warranty information.



Please read and understand these instructions completely before installation to avoid possible injury, or damage to the accessory or vehicle.

TOOLS NEEDED FOR INSTALLATION

- 10mm Socket or Wrench
- T-30 Torx Driver
- T-40 Torx Driver

PARTS LIST

- | | | |
|-------------------------------------|------------------------|------------------------|
| 1. X3-US10 Enclosure | 5. M6 x 25mm Screw x 1 | 9. B-Bracket x 1 |
| 2. B-H1220 Subwoofer Bridge Adapter | 6. Large washers x 2 | 10. Seat Risers x 2 |
| 3. M6 x 16mm Screws x 10 | 7. D-Brackets x 2 | 11. Small Spacer x 1 |
| 4. M6 Washers x 10 | 8. A-Bracket x 1 | 12. M6 Locking Hex Nut |
| | | 13. Foam Strips x 3 |

PARTS LIST IMAGES

				
1. X3-US10 Enclosure	2. B-H1220 Subwoofer Bridge Adapter	2. M6 x 16mm Screws x 10	3. M6 Washers x 10	4. M6 x 25mm Screw x 1
				
5. Large washers x 2	6. D-Brackets x 2	7. A-Bracket x 1	8. B-Bracket x 1	
				
9. Seat Risers x 2	10. Small Spacer x 1	11. M6 Locking Hex Nut	12. Foam Strips x 3	



A. Apply the foam strips to the inside right, left and top side of the enclosure.

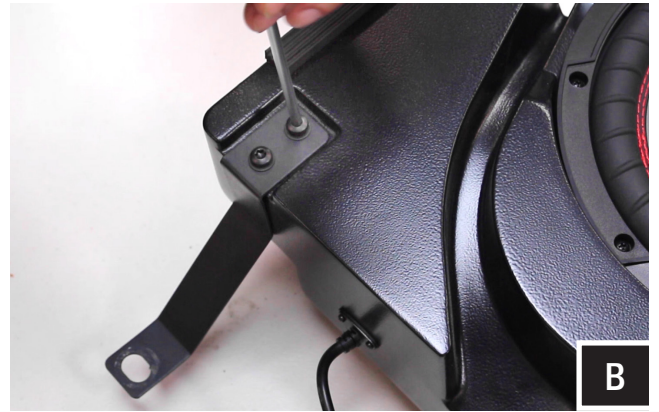

B. Using the supplied M6 screws and washers, screw the DD-brackets to the bottom right and left side of the enclosure.



C. Remove the factory 10mm nut and bolt from the brake line. Place the washer on top of the factory bracket and push the long M6x25mm screw through the top. Then attach the brake line, spacer, washer and nut. Then hand tighten.



D. Replace the factory seat bolt spacers with the supplied SSV Works spacers



E. Run the brake line along the dedicated channel on the sub enclosure while feeding the enclosure down under the seat bar (F1). Make any adjustments to the brake line so the enclosure lays on top of it. Line up the rear enclosure brackets to the rear seat bolts and press down until the brackets rest on top of the spacers.

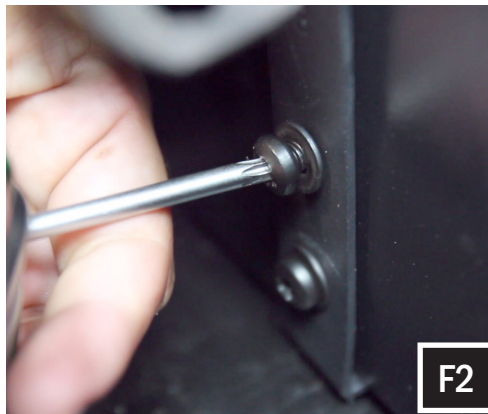

F. Place B-Bracket to the left side of the enclosure and slide the tab underneath the enclosure. (F1) Line up the 2 screw holes and proceed to hand thread the M6 screws and washers. Use a T30 Torx bit to tighten screws. Repeat for the right side. (F2) Line up the top of bracket A and B with the holes on the factory seat bracket. Screw in the M6 screw with the large washer (F3).

WIRING INSTRUCTIONS

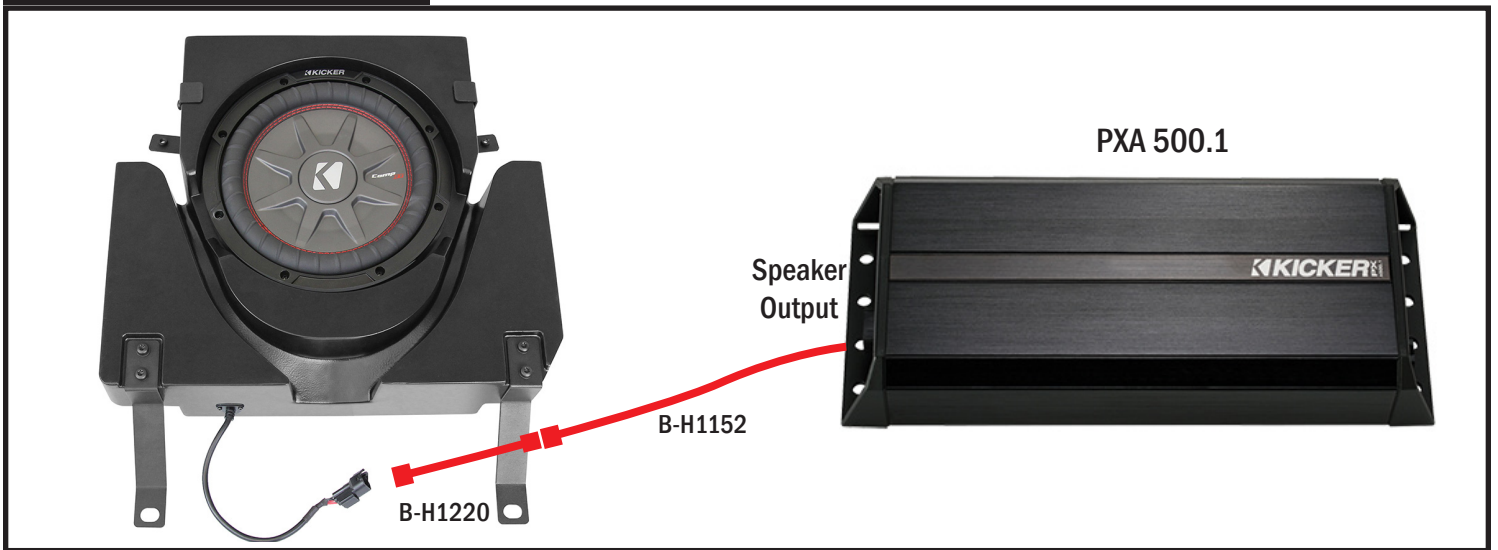



X3-F4

2017+ Can-Am Maverick x3 & x3 Max 4" Speaker Dash Pods

WARRANTY INFORMATION:

All SSV Works enclosures are covered by a limited lifetime warranty against defects in material or workmanship. All SSV Works Electronics are covered by a limited 1 year warranty against defects in material or workmanship. All SSV Works Speakers are covered by a limited 1 year warranty against defects in material or workmanship. Labor for replacement of defective components is not covered. Contact SSV Works for further warranty information.



Please read and understand these instructions completely before installation to avoid possible injury, or damage to the accessory or vehicle.

TOOLS NEEDED FOR INSTALLATION

- T-30 Torx Driver
- 10mm Wrench or Ratchet
- Drill 1/4" Drill bit
- Utility Knife

PARTS LIST

- | | |
|------------------------------|-------------------------|
| 1. X3-F4 Enclosures (1 pair) | 4. M6 x 25mm Screws x 2 |
| 2. Acoustic Lens (1 pair) | 5. M6 Washers x 6 |
| 3. M6 x 1.0 Screws x 4 | 6. 10mm Nut x 2 |

PARTS LIST IMAGES



1. X3-F4 Enclosures
(1 pair)



2. Acoustic Lens (1 pair)



3. M6 x 1.0 Screws x 4



4. M6 x 25mm Screws x 2



5. M6 Washers x 6



6. 10mm Nut x 2



A. Remove the top dash panels on the driver (7 screws with 2 clips) and passenger side (5 screws with 2 clips).



B. Pry off the (4) clips on the base under the empty space for the speaker

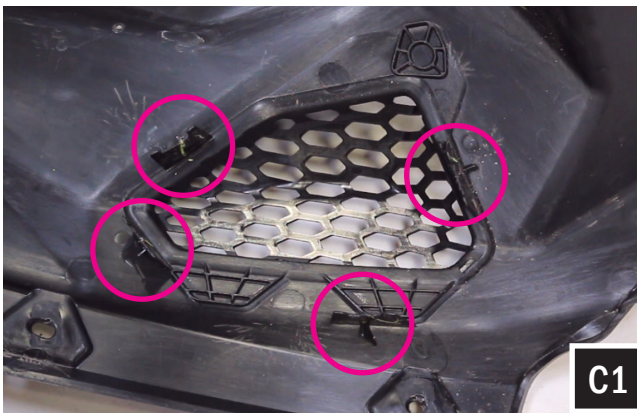

C. Using a utility knife, cut off the (4) tabs flush to the panel

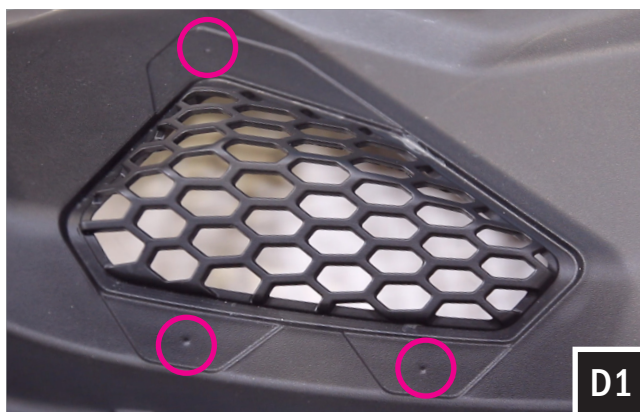

D. Drill a hole using a 1/4" drill bit at the factory dimple marks (as shown above) on the outside dash panel around the speaker grille.





E. Place the acoustic lens on top of the factory grille, line up the holes and insert the (2) top M6x1.0 (shorter) screws and washers.



F. Place the speaker pod under the dash panel and line up the holes on the speaker pod with the (2) top screws and loosely mount the pod to the dash panel.



G. Insert the M6x25mm screw by pushing it through the acoustic lens, dash panel and speaker pod. Secure screw using washer and 10mm nut. Now fasten the previous (2) M6x1.0 screws.



H. Installation is complete. Refer to wiring instruction below.

WIRING INSTRUCTIONS

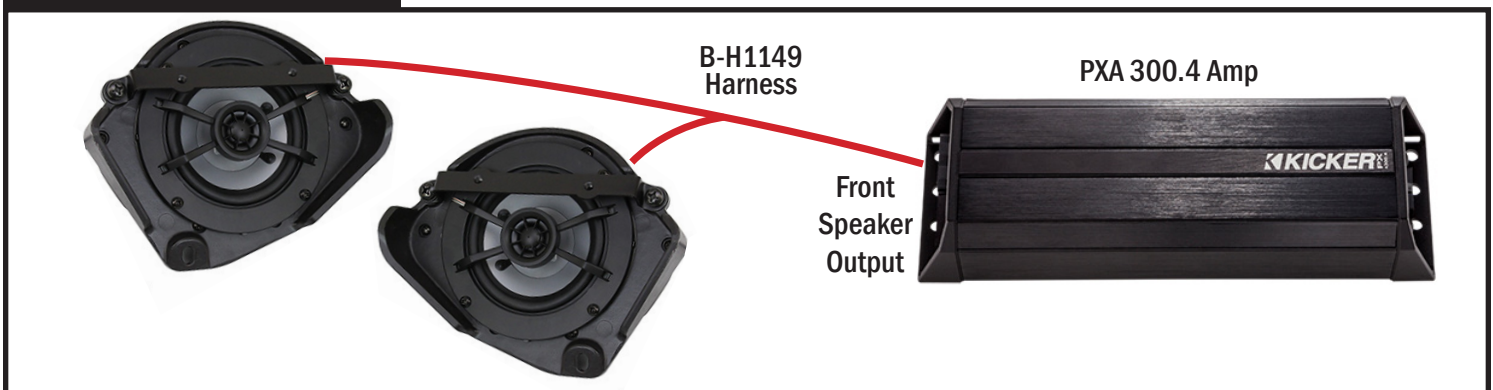



US-C65K

Universal Cage Mount 6.5" Speaker Enclosures

WARRANTY INFORMATION:

All SSV Works enclosures are covered by a limited lifetime warranty against defects in material or workmanship. All SSV Works Electronics are covered by a limited 1 year warranty against defects in material or workmanship. Labor for replacement of defective components is not covered. All SSV Works Speakers are covered by a limited 1 year warranty against defects in material or workmanship. Contact SSV Works for further warranty information.



Please read and understand these instructions completely before installation to avoid possible injury, or damage to the accessory or vehicle.

TOOLS NEEDED FOR INSTALLATION

- 5mm Allen Key

- 8mm Open End Wrench

PARTS LIST IMAGES



1. US-C65 Enclosures (1 pair)



2. Dual Mounting Ring Adapter x 2



3. Ring Clamp x 4



4. M6 Hex Head Bolts & Washers x4



5. M6 Allen Socket Head Bolts & Washers x4



6. M6 Set Screws x 4

INSTALLATION NOTES

The use of a thread locker is recommended on all screws to prevent loosening due to vibration. It is recommended to wrap the bag that the clamps come in around the cage before you slide the clamp onto the cage to prevent scratching.



A. Find the best orientation for the speaker on your bar and screw in the Set Screws in the OPPOSITE holes of where the clamp will install into.



B. Loosely install the clamp base to the cage mount pod with the two (2) M6 hex head bolts and washers, place the cage mount pod in the desired mounting location on the vehicle. Once the ring adapter is in the desired position, tighten the two (2) bolts using a 8mm open wrench.



C. Place both ring mounting clamps on the cage using the plastic bag to prevent scratching, place the cage mount pod in its final mounting location and secure to the clamps using the two (2) M6 allen socket head bolts and washers with a 5mm allen key.



D. Take the B-H1150 rear speaker harness and plug into the B-H1151 rear extension harness.

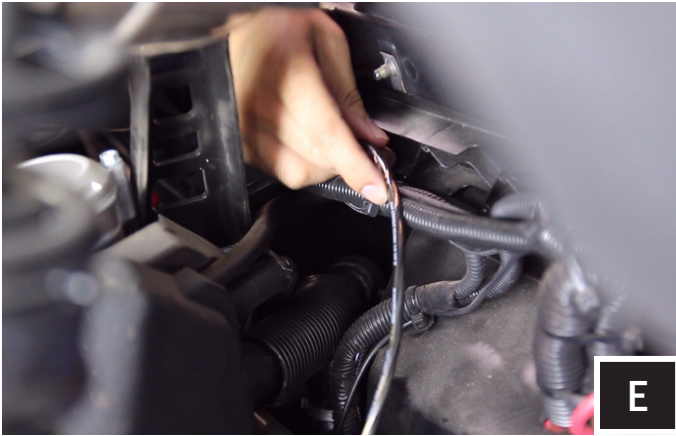

E. Route the rear speaker harness (B-H1150) along the factory wires in the engine compartment and pull up through the small space between the bed panel and cage tubing on both passenger and driver sides.

WIRING INSTRUCTIONS

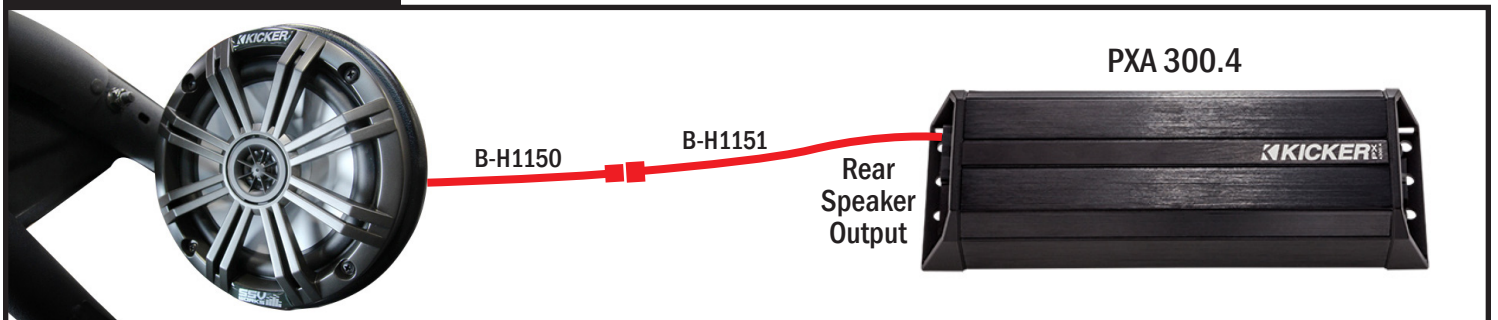

CONNECTING POWER & GROUND CABLE TO BATTERY



A



A

A. Unscrew the factory nut on the negative battery terminal. Install the 2 ground cables to the screw on the ground battery terminal. Re-install the factory nut.



B



B

B. Unscrew the factory nut on the positive battery terminal. Install the 2 power cables to the screw on the positive battery terminal. Re-install the factory nut.

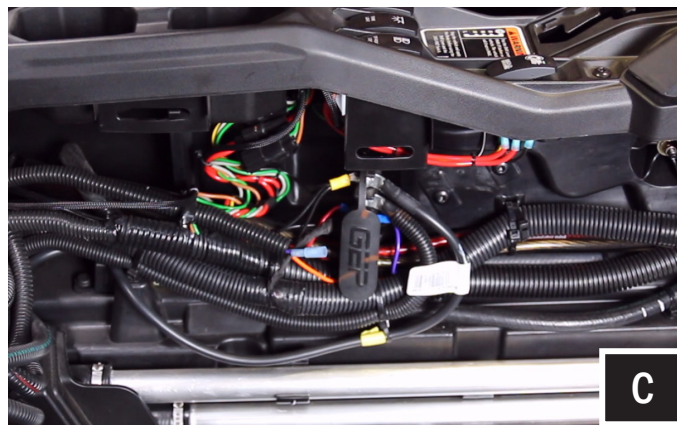

C

C. Zip tie all wiring to the factory cables away from any moving parts.

**THIS CONCLUDES THE INSTALLATION PROCESS. REPLACE THE FACTORY PANELS AND SEATS.
QUESTIONS? PLEASE CONTACT SSV WORKS AT 818-991-1778 OR EMAIL SUPPORT@SSVWORKS.COM**