

8

7

6

5

4

3

2

1

D

D

C

C

B

B

A

A

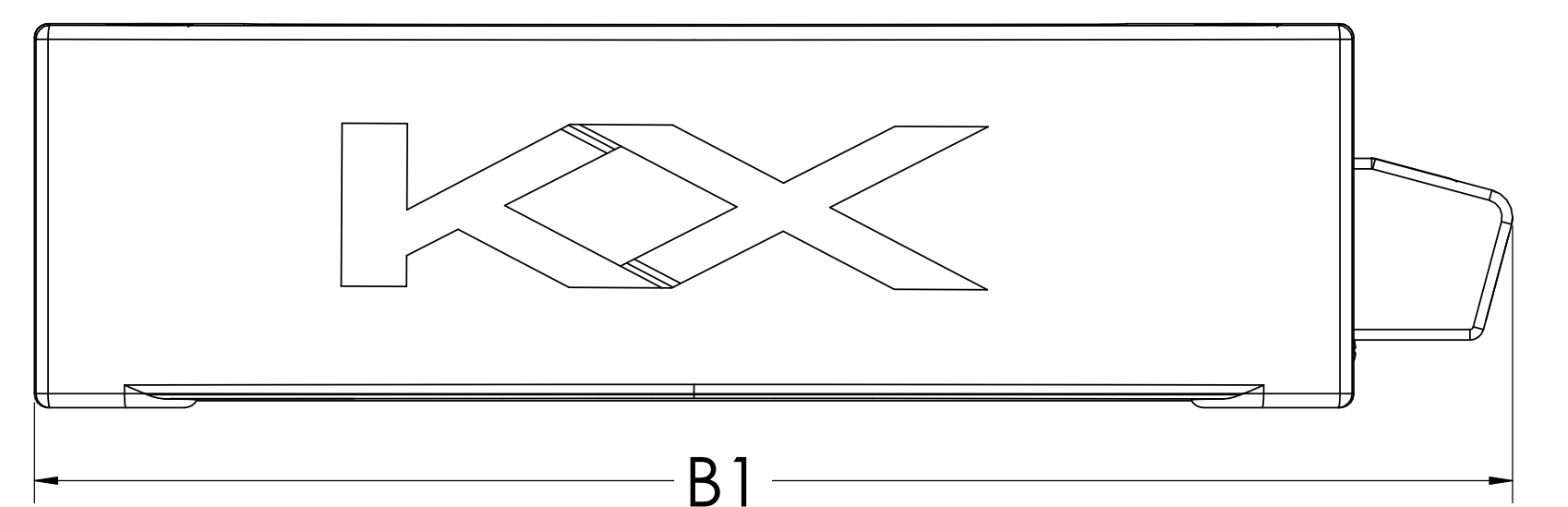
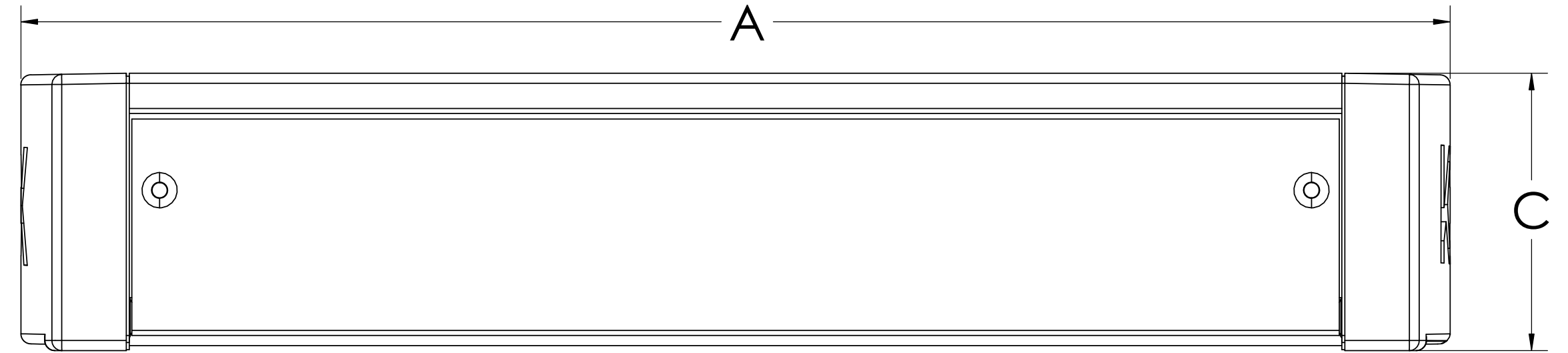
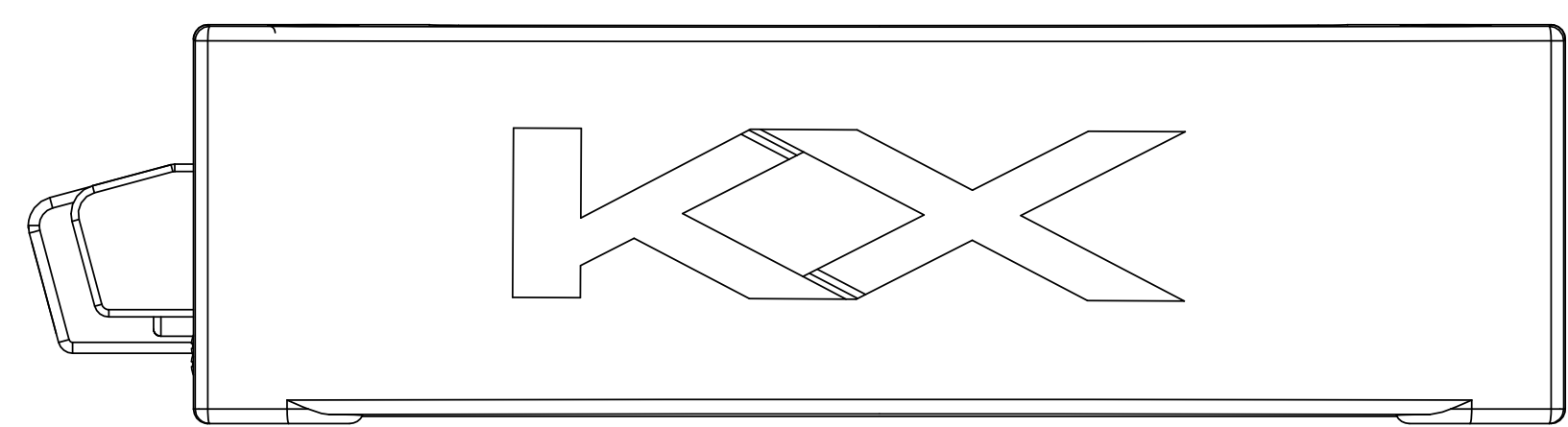
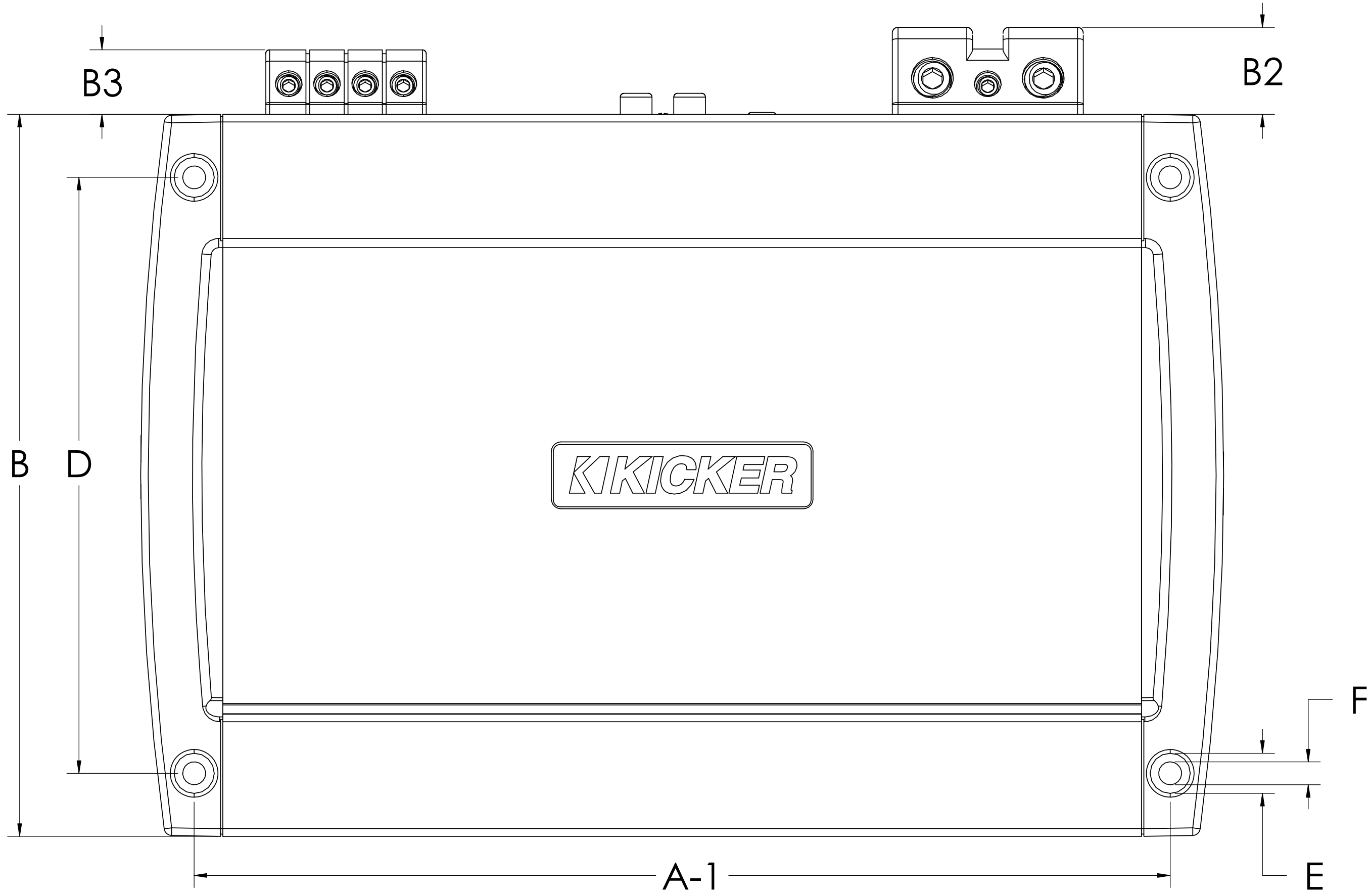

51KXMA15001 A-F CSD

PROPRIETARY AND CONFIDENTIAL
 THE INFORMATION CONTAINED IN THIS DRAWING IS THE SOLE PROPERTY OF <INSERT COMPANY NAME HERE>. ANY REPRODUCTION IN PART OR AS A WHOLE WITHOUT THE WRITTEN PERMISSION OF <INSERT COMPANY NAME HERE> IS PROHIBITED.

UNLESS OTHERWISE SPECIFIED:		DRAWN		NAME		DATE	
DIMENSIONS ARE IN INCHES		CHECKED					
TOLERANCES:		ENG APPR.					
FRACTIONAL ±		MFG APPR.					
ANGULAR: MACH ± BEND ±		Q.A.					
TWO PLACE DECIMAL ±		COMMENTS:					
THREE PLACE DECIMAL ±							
INTERPRET GEOMETRIC TOLERANCING PER:							
MATERIAL							
FINISH							
NEXT ASSY		USED ON					
APPLICATION		DO NOT SCALE DRAWING					

TITLE: KXMA1500.1 CSD

SIZE DWG. NO. REV
D 1 1

SCALE: 1:1 WEIGHT: SHEET 1 OF 2

8

7

6

5

4

3

2

1

8 7 6 5 4 3 2 1

D
C
B
A

D
C
B
A

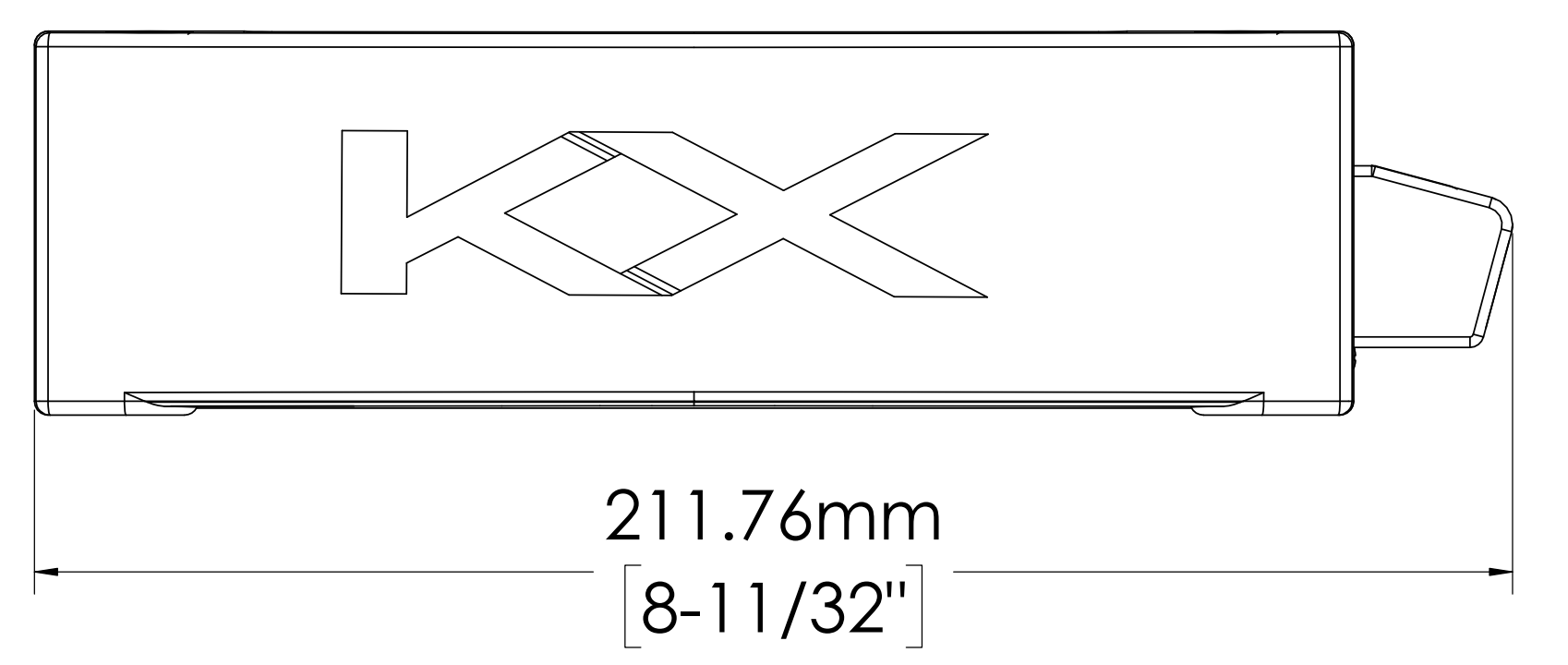
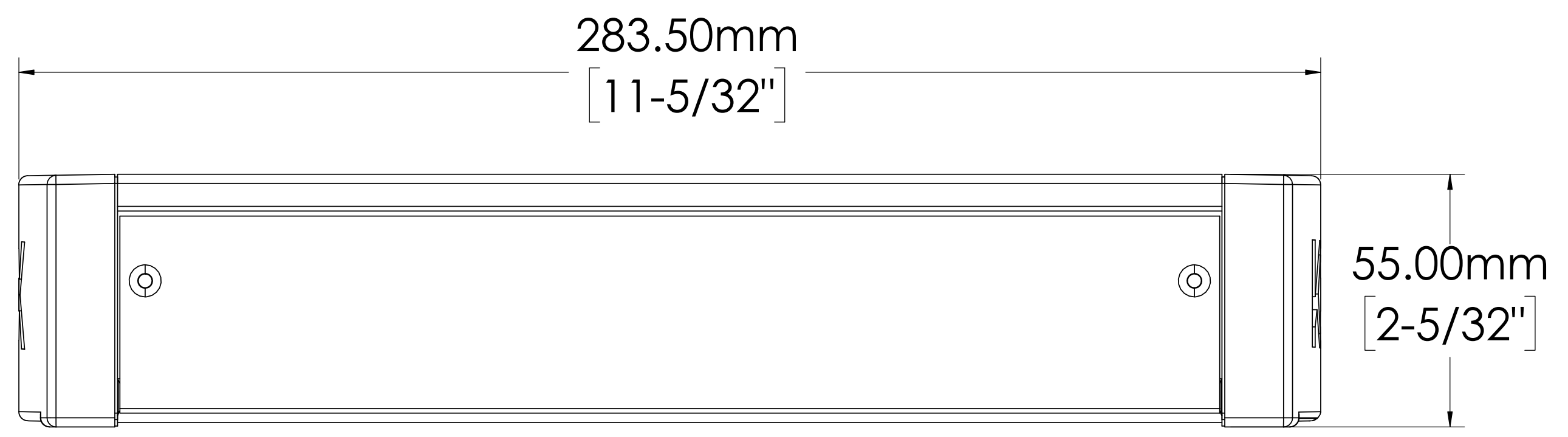
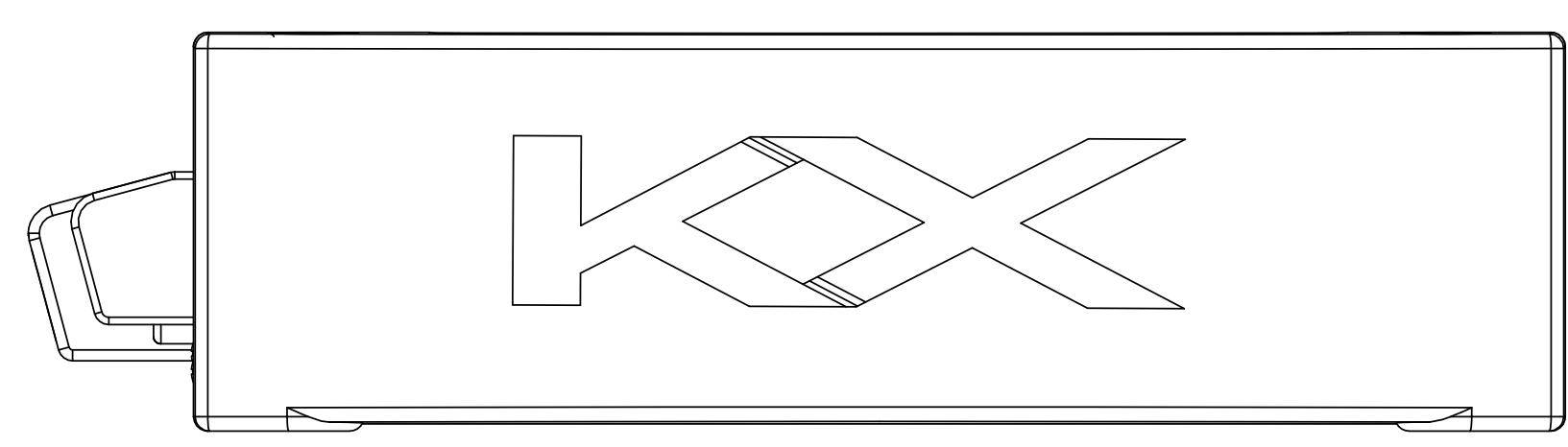
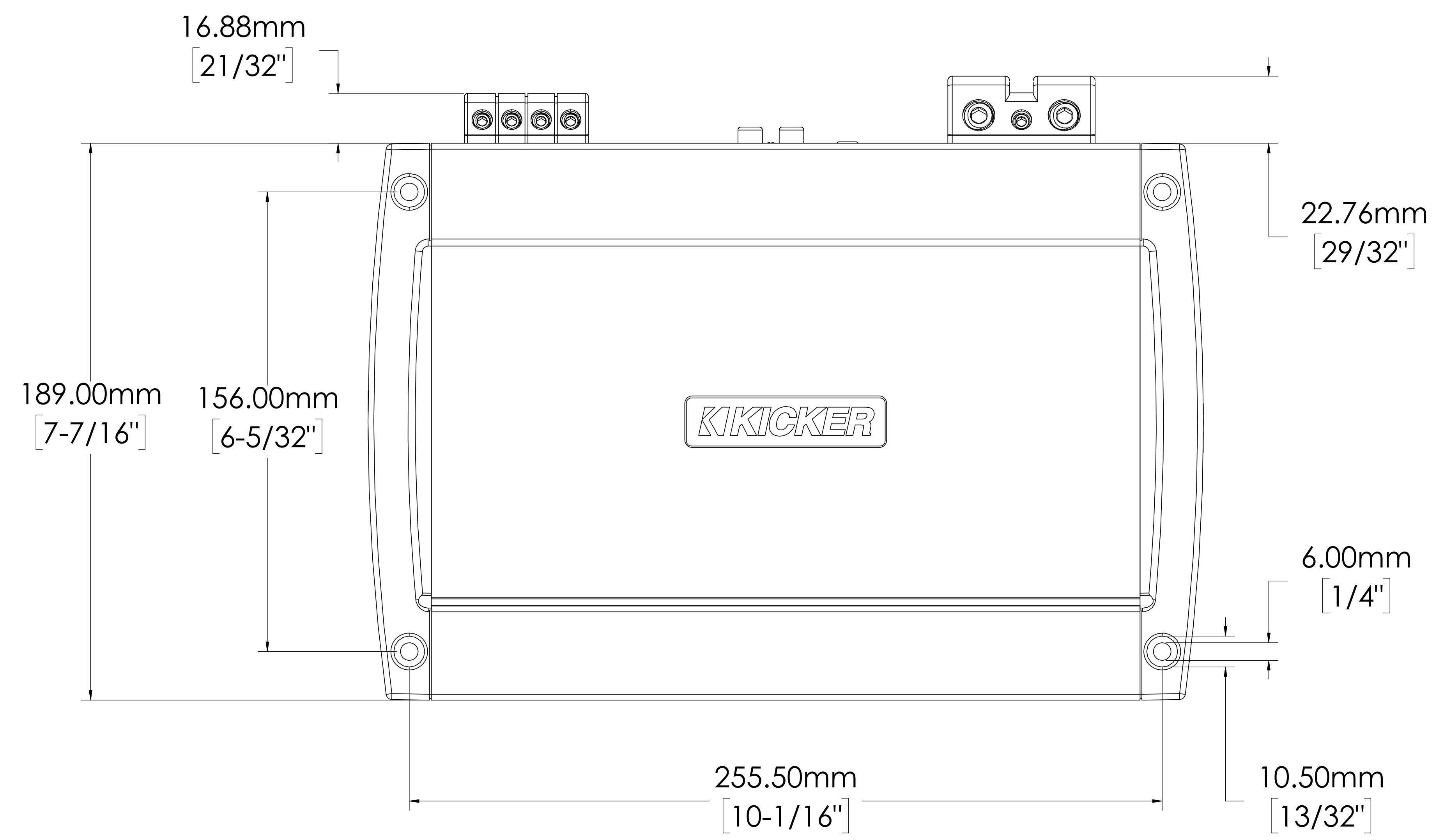

51KXMA15001
DIMENSIONAL
REFERENCE DRAWING

PROPRIETARY AND CONFIDENTIAL
THE INFORMATION CONTAINED IN THIS
DRAWING IS THE SOLE PROPERTY OF
©BERT COMPANY NAME HERE. ANY
REPRODUCTION IN PART OR AS A WHOLE
WITHOUT THE WRITTEN PERMISSION OF
©BERT COMPANY NAME HERE IS
PROHIBITED.

UNLESS OTHERWISE SPECIFIED:		DRAWN		NAME		DATE	
DIMENSIONS ARE IN INCHES		CHECKED				TITLE:	
FRACTIONAL ±		ENG APPR.				KXMA1500.1 CSD	
ANGULAR: MACH ± BEND ±		MFG APPR.				SIZE DWG. NO. REV	
TWO PLACE DECIMAL ±		Q.A.				D	
THREE PLACE DECIMAL ±		COMMENTS:				SCALE: 1:1 WEIGHT: SHEET 2 OF 2	
INTERPRET GEOMETRIC TOLERANCING PER:		MATERIAL					
FINISH		APPLICATION					
NEXT ASSY USED ON		DO NOT SCALE DRAWING					

8 7 6 5 4 3 2 1