

15.00mm
[9/16"]

48.00mm
[1-7/8"]

DRILL 4 HOLES
 \varnothing 2.00mm
[1/16"]

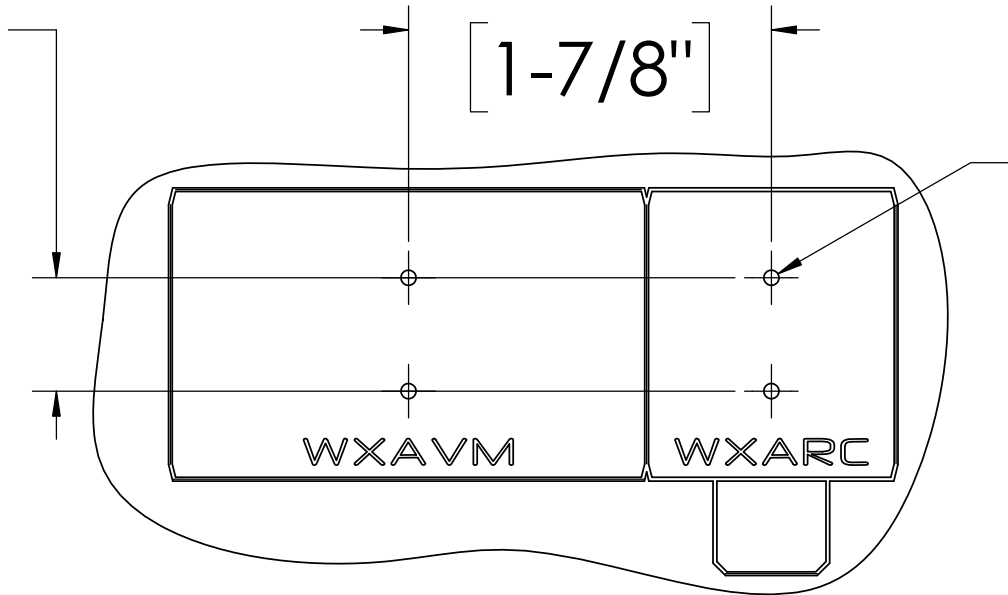

BOTTOM MOUNT

MINIMUM PANEL
THICKNESS (STEEL) 1.50mm
[1/16"]

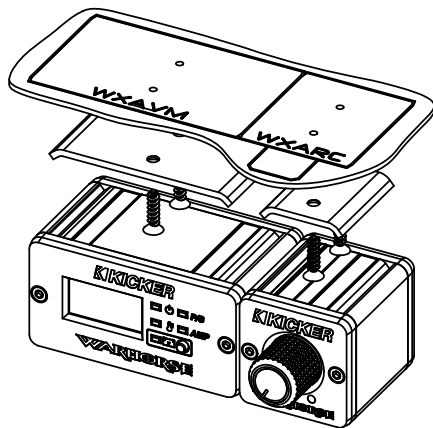

TOP MOUNT

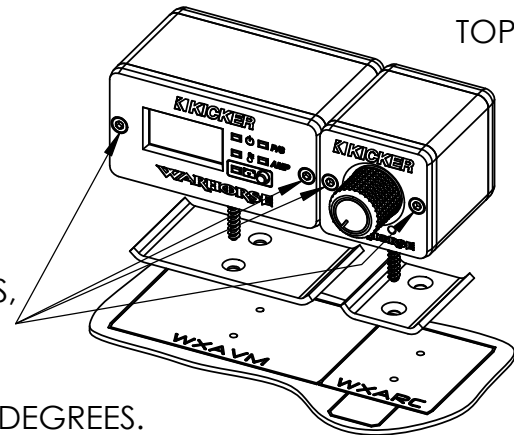

- FOR TOP MOUNT APPLICATIONS,
1) REMOVE THESE 4 SCREWS.
2) SEPARATE FRONT ASSEMBLY
FROM REAR ASSEMBLY
3) ROTATE REAR ASSEMBLY 180 DEGREES.
4) REINSTALL 4 SCREWS.