

# KICKER®

**Owner's Manual**  
**Manual del Propietario**  
**Manuel d'utilisatio**  
**Benutzerhandbuch**

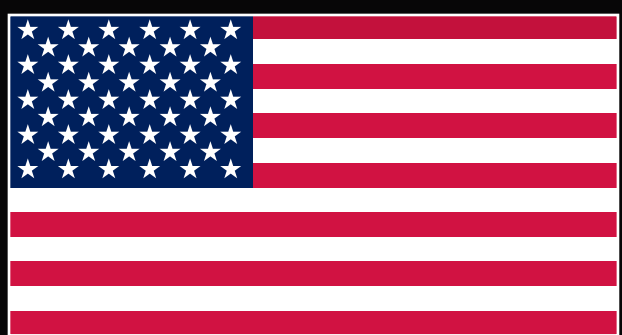

*select language*



MSC Coaxials



*seleccione  
el idioma*

Altavoz Coax MSC

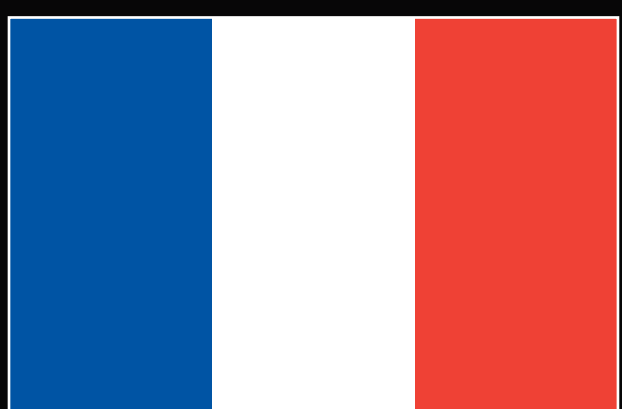

*choisir la  
langue*

Haut-parleurs  
Coaxiaux MSC



*sprache  
auswählen*

MSC Koax-System



# Contents

---

Overview .....	3
Specifications .....	4
Installation .....	5
Wiring Configuration.....	5
LED Wiring Configuration .....	6
Mounting.....	7
Grille Installation .....	10
Warranty .....	13
Garantía   Garantie .....	

# Overview

---

## **IMPORTANT SAFETY WARNING**

PROLONGED CONTINUOUS OPERATION OF AN AMPLIFIER, SPEAKER, OR SUBWOOFER IN A DISTORTED, CLIPPED OR OVER-POWERED MANNER CAN CAUSE YOUR AUDIO SYSTEM TO OVERHEAT, POSSIBLY CATCHING FIRE AND RESULTING IN SERIOUS DAMAGE TO YOUR COMPONENTS AND/OR VEHICLE. AMPLIFIERS REQUIRE UP TO 4 INCHES (10CM) OPEN VENTILATION. SUBWOOFERS SHOULD BE MOUNTED WITH AT LEAST 1 INCH (2.5CM) CLEARANCE BETWEEN THE FRONT OF THE SPEAKER AND ANY SURFACE. KICKER PRODUCTS ARE CAPABLE OF PRODUCING SOUND LEVELS THAT CAN PERMANENTLY DAMAGE YOUR HEARING! TURNING UP A SYSTEM TO A LEVEL THAT HAS AUDIBLE DISTORTION IS MORE DAMAGING TO YOUR EARS THAN LISTENING TO AN UNDISTORTED SYSTEM AT THE SAME VOLUME LEVEL. THE THRESHOLD OF PAIN IS ALWAYS AN INDICATOR THAT THE SOUND LEVEL IS TOO LOUD AND MAY PERMANENTLY DAMAGE YOUR HEARING. PLEASE USE COMMON SENSE WHEN CONTROLLING VOLUME.

The KICKER Premium Marine MSC speakers are the best premium full-range speakers for marine and outdoor environments ever engineered. The speaker assembly is fully sealed, including around the speaker and LED connections to ensure the easiest installation possible while maintaining mechanical and electrical integrity. Whether upgrading an existing audio system or decking out a new one, these coaxial speakers can be mounted anywhere you need top-quality audio that can take the punishment of being out on the open water or exposed to the elements. As always, KICKER uses advanced materials and construction techniques to ensure optimal performance for years to come. We hope you have the chance to combine these new coaxial speakers with our whole line of premium marine products, including subwoofers and amplifiers, for the best audio experience money can buy!

# Specifications

<b>MSC Coaxial Speakers</b>	<b>MSC65</b>	<b>MSC8</b>
Woofer [in, mm]	6-1/2, 165	8, 200
Peak Power Handling [ Watts]	200	400
Recommended Amplifier Power [Watts RMS]	15-100	15-200
Sensitivity [1W, 1m]	89	90.5
Frequency Response [Hz]	55–25k	45–25k
Mounting Hole Diameter [in, mm]	5-7/16, 139	6-9/16, 167
Mounting Depth [in, mm]	3-1/4, 83	3-1/2, 89

## **Specifications Common to All Models**

Tweeter [in, mm]	1-1/8, 28
Rated Impedance [ $\Omega$ ]	4
Tweeter Magnet Material	Neodymium
Tweeter Dome Material	Teteron
Tweeter Design	Textile Dome
Woofer Cone Material	Polypropylene & Carbon Fiber
Woofer Surround Material	Santoprene
Grilles	Yes

**Note:** All specifications and performance figures are subject to change. Please visit [www.kicker.com](http://www.kicker.com) for the most current information. To get the best performance from your new KICKER speakers, we recommend using genuine KICKER accessories and wiring. Please allow two weeks of break-in time for the speakers to reach optimum performance.



# Installation

---

## Wiring Configuration

We recommend using 16 gauge (or larger) wire. The MSC Speakers are rated at 4 ohms and work with any source unit or amplifier designed to operate at a 4 ohm load. **Make sure your source unit or amplifier is rated for 4 ohm operation.** Carefully run the speaker wire in a location that is clear of standing water and moving components of the boat. At least two amplifier channels are needed for stereo operation

1. Connect the MSC speaker leads to the speaker output terminals of your amplifier.
  - a. CLEAR BLUE WIRE - POSITIVE (+)
  - b. CLEAR BLACK WIRE - NEGATIVE (-)
2. Connect the MSC audio & LED plugs to the MSC.

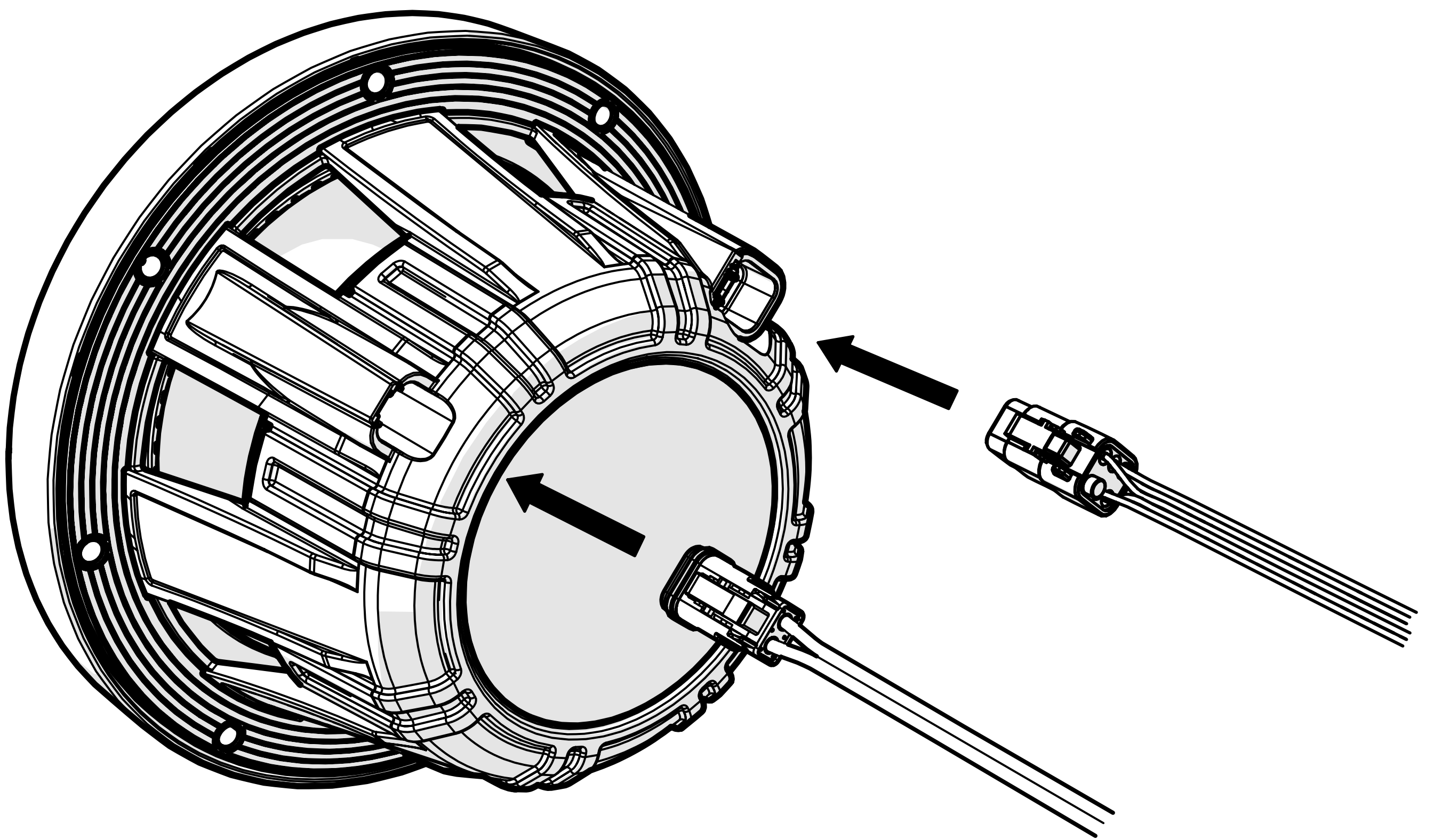

**Pro Tip:** You're a KICKER [KXM amplifier](#) and [a few cables](#) away from a full system upgrade that will dominate any factory system! Also, ask your [KICKER Dealer](#) about KICKER Premium Marine subwoofer upgrades.



# LED Wiring Configuration

When wiring the LED lighting, the black lead is +12V and the blue, red, green and white leads are ground.

1. Connect the black LED wire to the positive terminal of the battery.

a. Place a 2-amp fuse (not included) no further than 7" away from the battery terminal.

b. Install a switch (not included) on the black LED wire between the fuse and the speaker, so the LED's can be turned off. Without a switch to turn them off, they will always be on.

2. Connect the red, blue, green, and/or white LED wires to the negative terminal of the battery. See the chart below for available combinations.

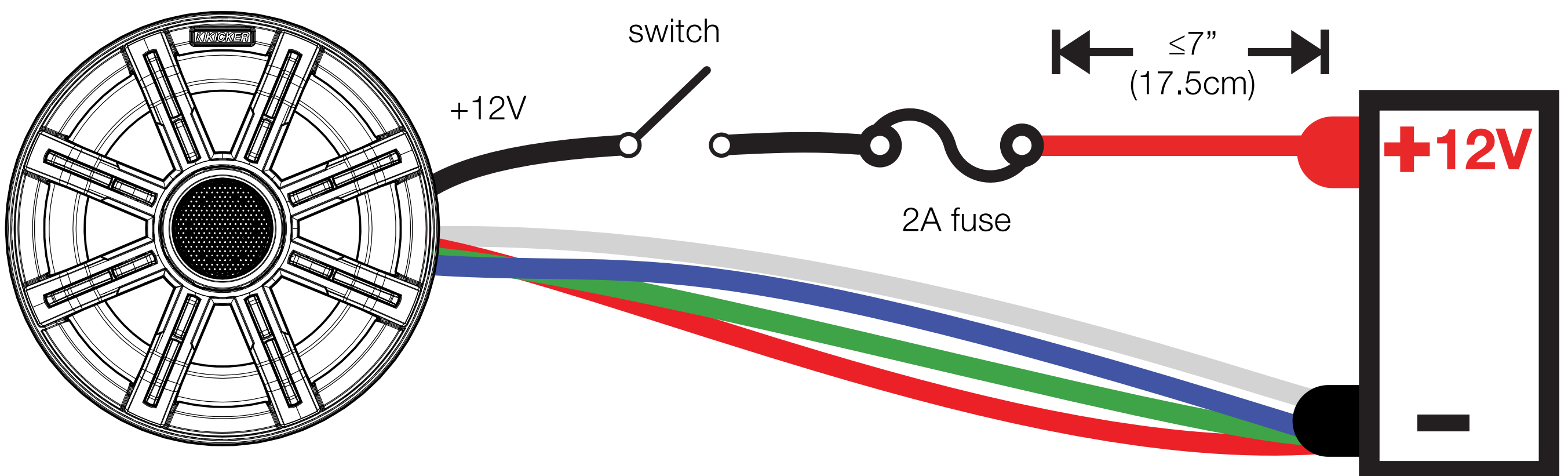

**Color Combinations:** Splice and combine the ground wires to yield a different color.

Wires Connected to Negative Terminal	LED Color
Red	Red
Green	Green
Blue	Blue
White	White
Red/Green	Lime Green
Red/Blue	Magenta
Blue/Green	Aquamarine
Red/Green/Blue	Blue-White



# Mounting

The sound produced by the MSC coaxials is directional. Find the best location for stereophonic sound. If necessary, add more MSC coaxial speakers to the system to help distribute and balance the sound-stage.

After determining the best mounting locations, carefully check the areas where the mounting hardware will be placed. If a mounting location does not already exist, cut a hole in the desired location using the templates from the [MSC product page](#) at KICKER.com. If necessary, pre-drill the mounting screw holes using a 7/64" (2.5mm) bit following the template.

Use masking tape to help prevent damage to the paint in the locations to be cut or drilled. If you are mounting the speaker to a surface made from thin, soft material such as aluminum, use the provided stainless steel speed nuts to provide threads for the stainless steel mounting screws. If the speaker cut-out locations require you to cut metal, avoid structural metal and braces. If the panel cannot support the weight of the speaker, an optional reinforcing ring may be fastened or adhered to it.



Make sure the mounting screws and speed nuts will not puncture the fuel cell, wiring, or interfere with any mechanical parts on the underside of the mounting surface. If the supplied hardware is not applicable to your installation, some other means of securely attaching the speakers to the boat must be used.

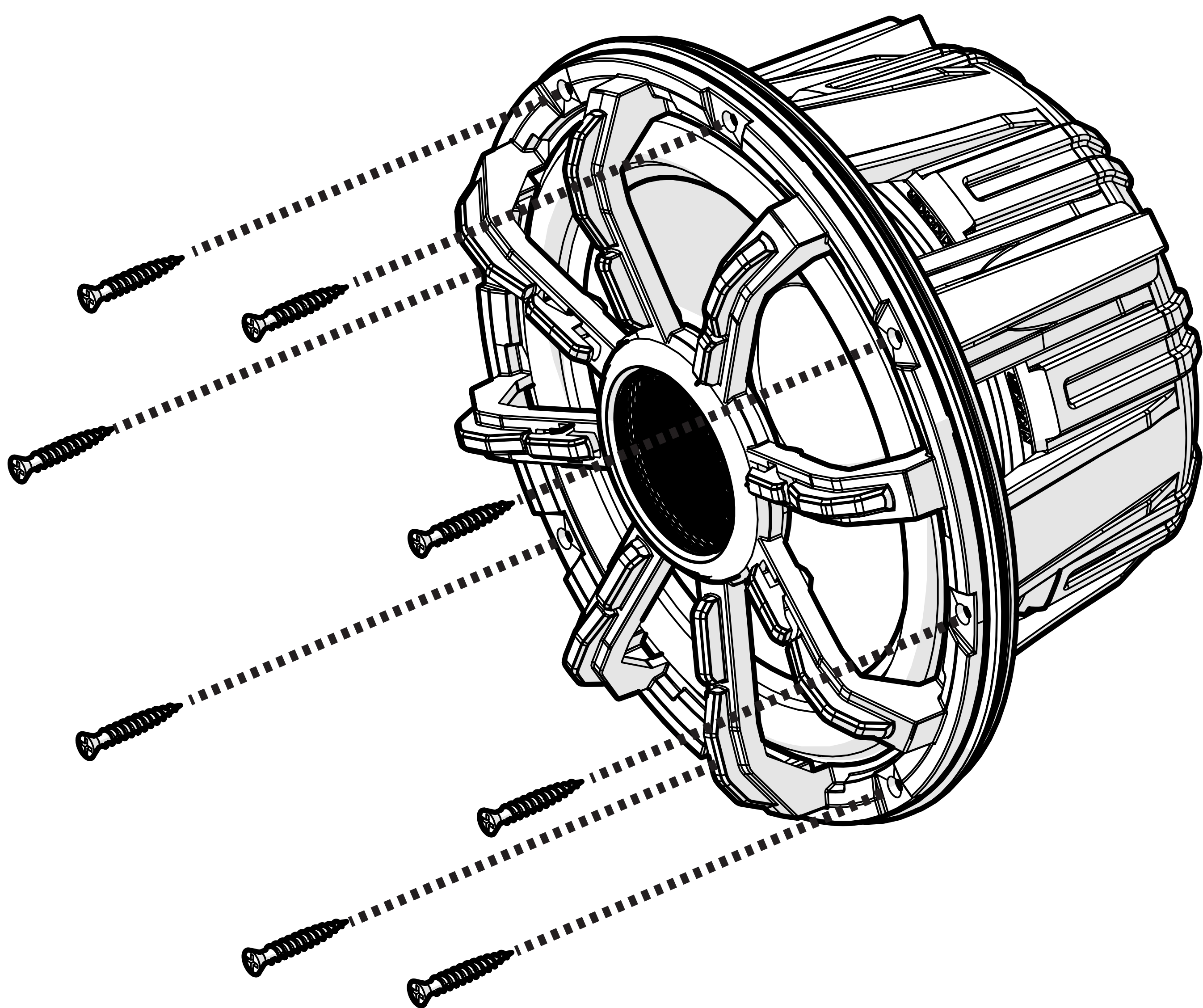



# Secure speaker to desired location. Possible locations for MSC Speaker Mounting

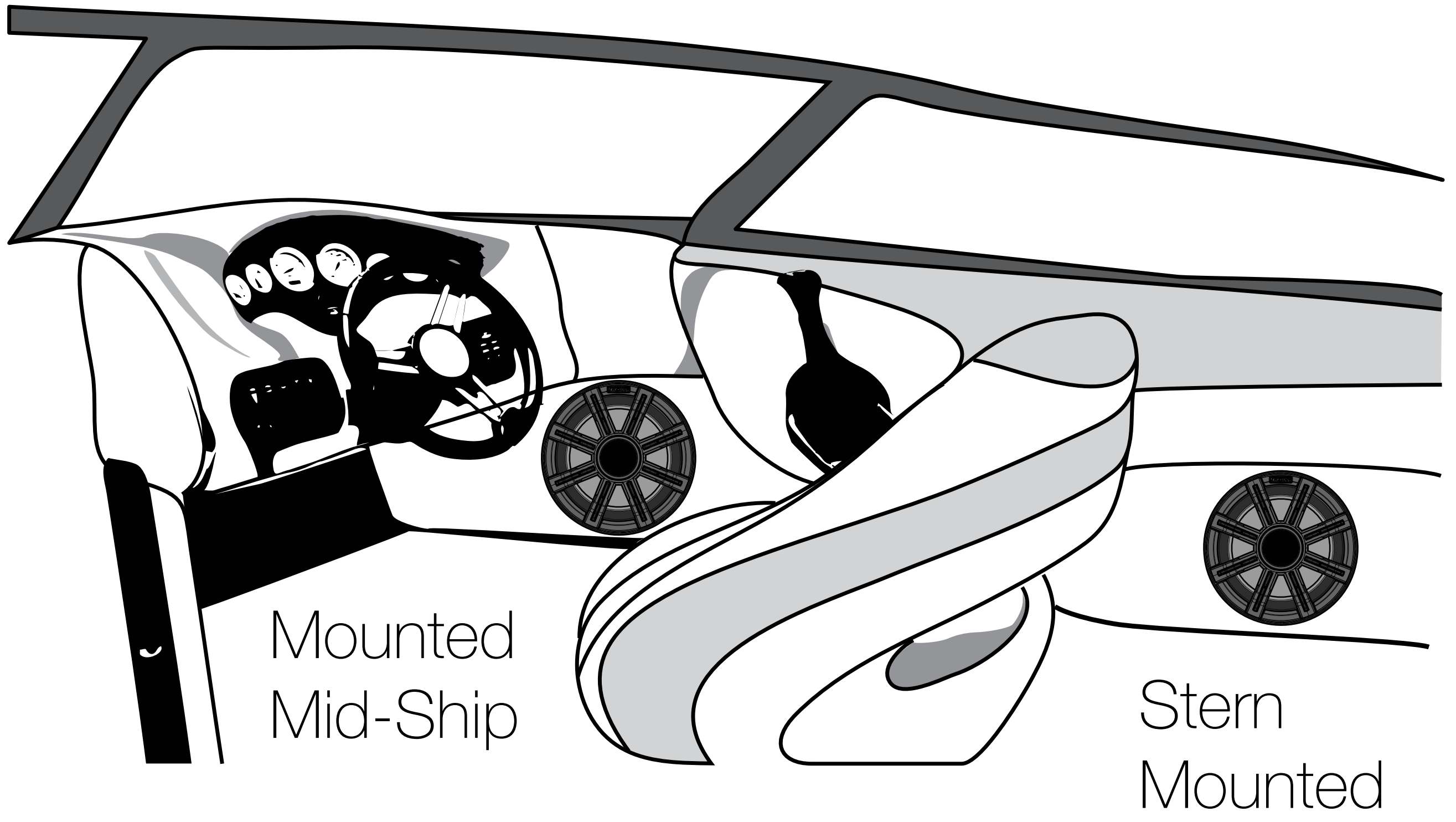

Mounted in the Bow

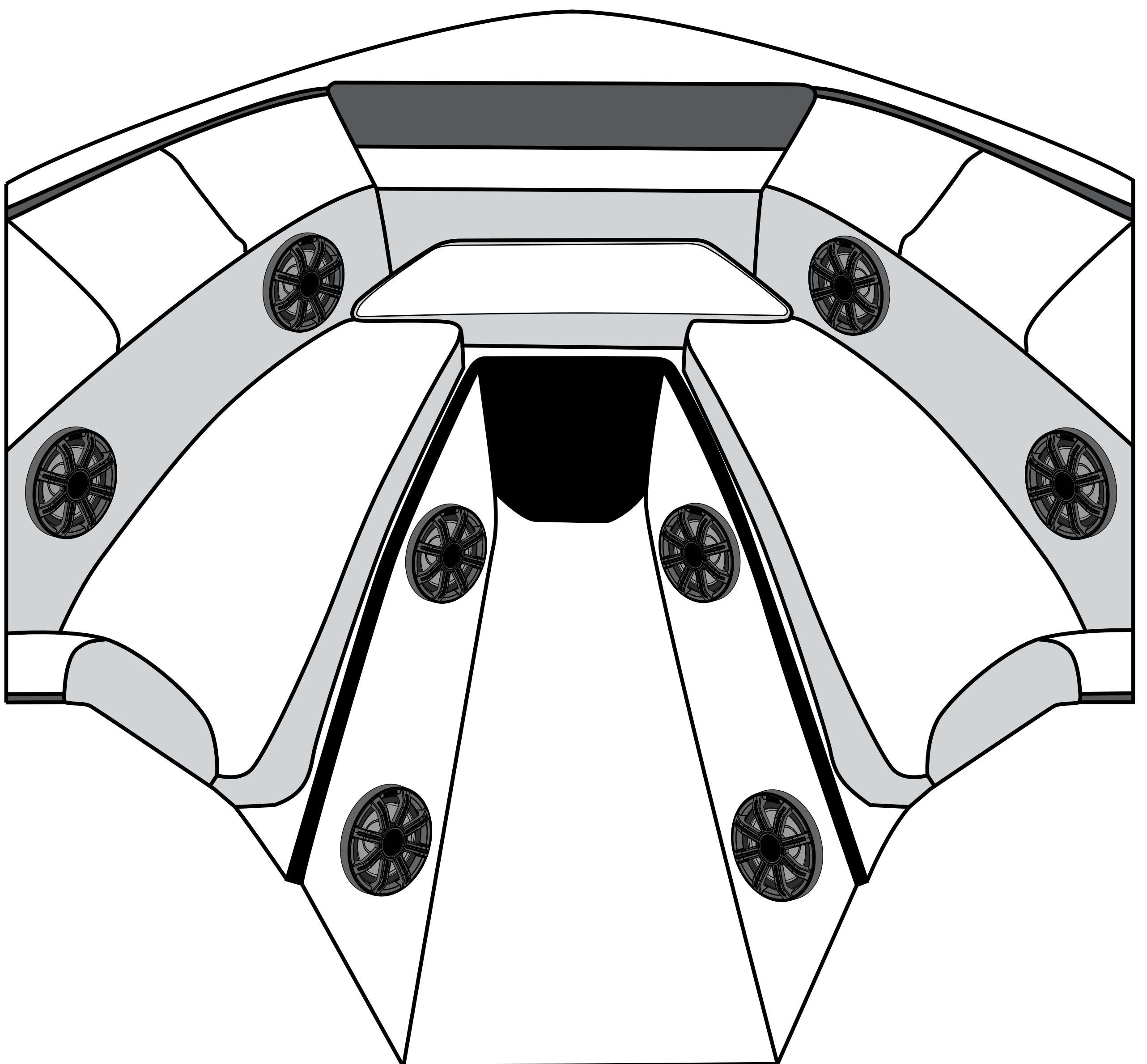



# Grille Installation

The MSC Speaker Grille is a snap-lock configuration that must be correctly oriented to be installed properly. To do this, make sure the KICKER badge logo at the top of the grille is in the same orientation as the KICKER "K" logo located on the tweeter bridge, directly above the tweeter.

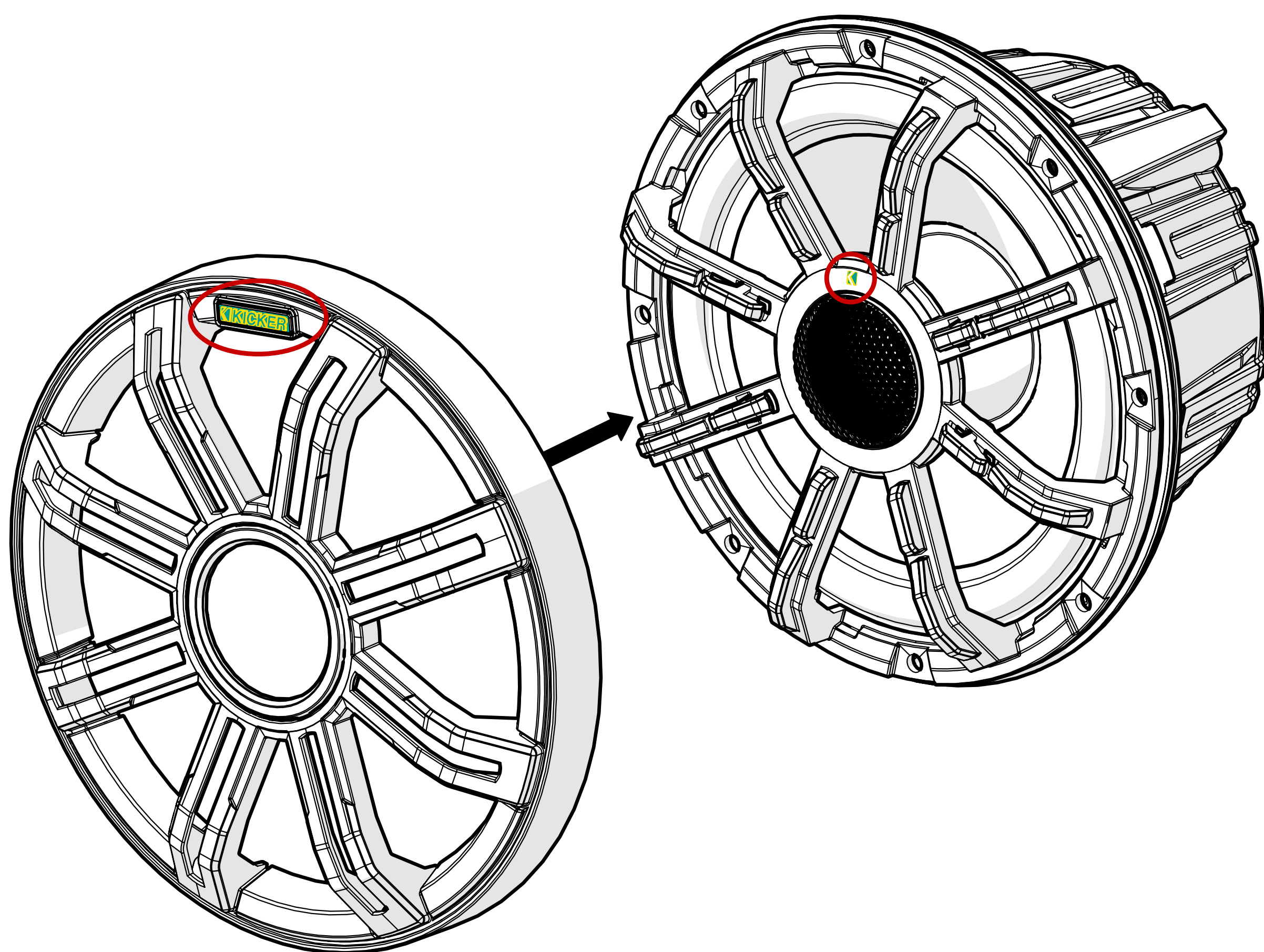

Apply pressure to the inner ring at the 3-o'clock & 9-o'clock positions, indicated by the red arrows. This will engage the snap-lock locations indicated by the red circles.

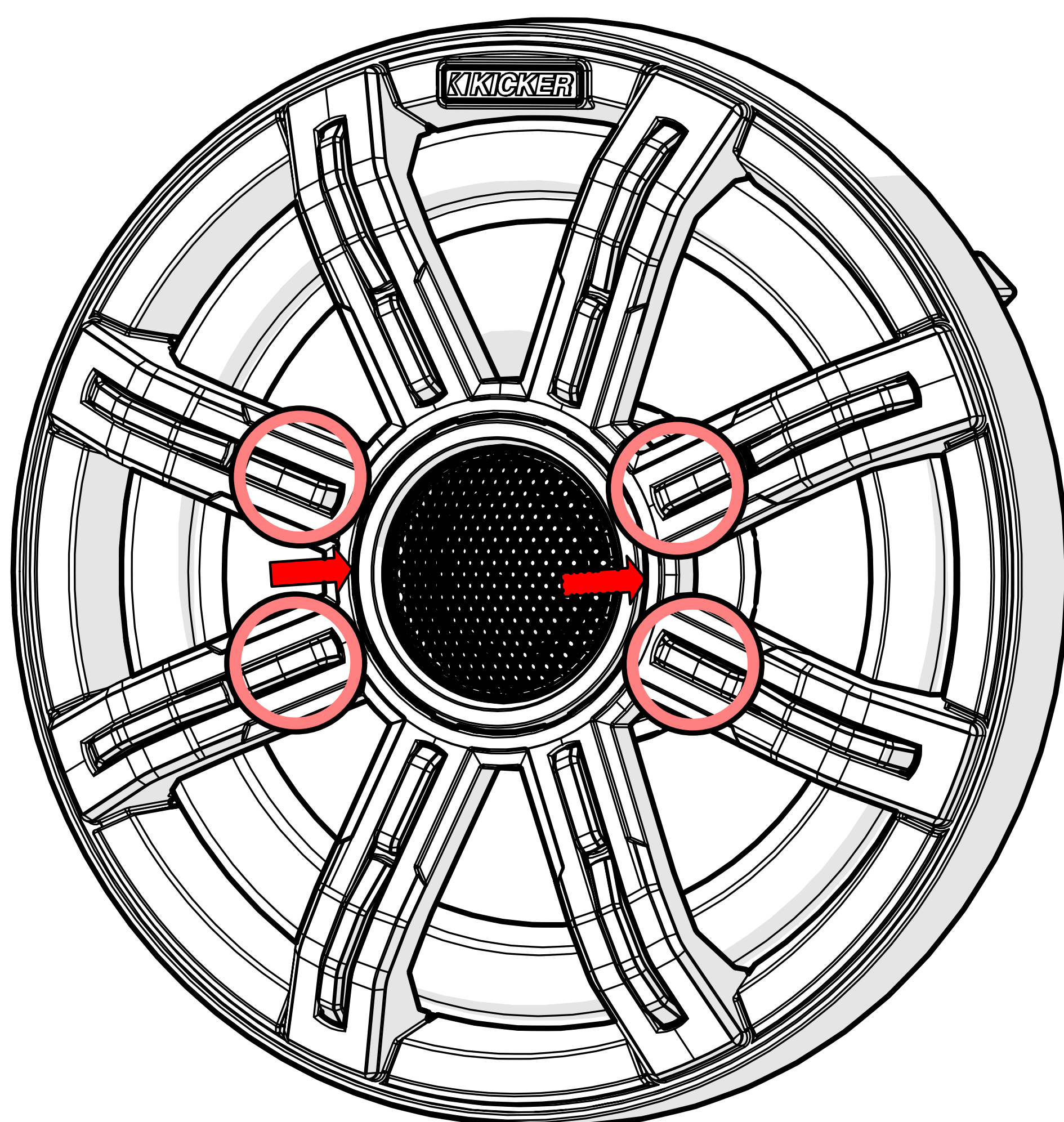



# Warranty

---

When purchased from an Authorized KICKER Dealer, KICKER warrants this product to be free from defects in material and workmanship under normal use for a period of THREE (3) YEARS from date of original purchase with receipt. If this product is identified as “Refurbished” or “B Goods”, the warranty is limited to a period of THREE (3) MONTHS from the date of original purchase. In all cases you must have the original receipt. Should service be necessary under this warranty for any reason due to manufacturing defect or malfunction during the warranty period, KICKER will repair or replace (at its discretion) the defective merchandise with equivalent merchandise. Warranty replacements may have cosmetic scratches and blemishes. Discontinued products may be replaced with more current equivalent products. This warranty is valid only for the original purchaser and is not extended to owners of the product subsequent to the original purchaser. Any applicable implied warranties are limited in duration to a period of the express warranty as provided herein beginning with the date of the original purchase at retail, and no warranties, whether express or implied, shall apply to this product thereafter. Some states do not allow limitations on implied warranties; therefore, these exclusions may not apply to you. This warranty gives you specific legal rights; however you may have other rights that vary from state to state.

## **WHAT TO DO IF YOU NEED WARRANTY OR SERVICE:**

Defective merchandise should be returned to your local Authorized Stillwater Designs (KICKER) Dealer for warranty service. Assistance in locating an Authorized Dealer can be found at [www.KICKER.com](http://www.KICKER.com) or by contacting Stillwater Designs directly. You can confirm that a dealer is authorized by asking to see a current authorized dealer window decal.

If it becomes necessary for you to return defective merchandise directly to Stillwater Designs (KICKER), call the KICKER Customer Service Department at (405) 624-8510 for a Return Merchandise Authorization (RMA) number. Package only the defective items in a package that will prevent shipping damage, and return to:

**Stillwater Designs**  
**3100 North Husband St**  
**Stillwater, OK 74075**

The RMA number must be clearly marked on the outside of the package. Please return only defective components. The return of functioning items increases your return freight charges. Non-defective items will be returned freight collect to you. For example, if a subwoofer is defective, only return the defective subwoofer, not the entire enclosure. Include a copy of the original receipt with the purchase date clearly visible, and a “proof-of-purchase” statement listing the Customer’s name, Dealer’s name and invoice number, and product purchased. Warranty expiration on items without proof-of-purchase will be determined from the type of sale and manufacturing date code. Freight must be prepaid; items sent freight-collect, or COD, will be refused.

## **WHAT IS NOT COVERED?**

This warranty is valid only if the product is used for the purpose for which it was designed. It does not cover:

- o Damage due to improper installation
- o Subsequent damage to other components
- o Damage caused by exposure to moisture, excessive heat, chemical cleaners, and/or UV radiation
- o Damage through negligence, misuse, accident or abuse. Repeated returns for the same damage may be considered abuse
- o Any cost or expense related to the removal or reinstallation of product
- o Speakers damaged due to amplifier clipping or distortion
- o Items previously repaired or modified by any unauthorized repair facility
- o Return shipping on non-defective items
- o Products with tampered or missing barcode labels
- o Products with tampered or missing serial numbers
- o Products returned without a Return Merchandise Authorization (RMA) number
- o Products purchased from an UNAUTHORIZED dealer
- o Freight Damage
- o The cost of shipping product to KICKER
- o Service performed by anyone other than KICKER

## **HOW LONG WILL IT TAKE?**

KICKER strives to maintain a goal of one-week service for all acoustics (subwoofers, midrange drivers, tweeters, crossovers, etc) returns. Delays may be incurred if lack of replacement inventory or parts is encountered. Failure to follow these steps may void your warranty. Any questions can be directed to the KICKER Customer Service Department at (405) 624-8510. Contact your International KICKER dealer or distributor concerning specific procedures for your country’s warranty policies.



# Garantía | Garantie

---

Contact your International KICKER dealer or distributor concerning specific procedures for your country's warranty policies.

Our goods come with guarantees that cannot be excluded under the **Australian Consumer Law**. You are entitled to a replacement or refund for a major failure and for compensation for any other reasonably foreseeable loss or damage. You are also entitled to have the goods repaired or replaced if the goods fail to be of acceptable quality and the failure does not amount to a major failure.

## **GARANTÍA INTERNACIONAL**      **Versión Español**

Comuníquese con su concesionario o distribuidor KICKER internacional para obtener información sobre procedimientos específicos relacionados con las normas de garantía de su país.

La frase "combustible para vivir la vida Livin' Loud™ a todo volumen" se refiere al entusiasmo por la vida que la marca KICKER de estéreos de automóvil representa y a la recomendación a nuestros clientes de que vivan lo mejor posible ("a todo volumen") en todo sentido. La línea de altavoces y amplificadores KICKER es la mejor del mercado de audio de automóviles y por lo tanto representa el "combustible" para vivir a todo volumen en el área de "estéreos de automóvil" de la vida de nuestros clientes. Recomendamos a todos nuestros clientes que obedezcan todas las reglas y reglamentos locales sobre ruido en cuanto a los niveles legales y apropiados de audición fuera del vehículo.

## **INTERNATIONALE GARANTIE**      **Deutsche Version**

Nehmen Sie mit Ihren internationalen KICKER-Fachhändler oder Vertrieb Kontakt auf, um Details über die Garantieleistungen in Ihrem Land zu erfahren.

Der Slogan "Treibstoff für Livin' Loud" bezieht sich auf die mit den KICKER-Autostereosystemen assoziierte Lebensfreude und die Tatsache, dass wir unsere Kunden ermutigen, in allen Aspekten ihres Lebens nach dem Besten ("Livin' Loud") zu streben. Die Lautsprecher und Verstärker von KICKER sind auf dem Markt für Auto-Soundsysteme führend und stellen somit den "Treibstoff" für das Autostereoerlebnis unserer Kunden dar. Wir empfehlen allen unseren Kunden, sich bezüglich der zugelassenen und passenden Lautstärkepegel außerhalb des Autos an die örtlichen Lärmvorschriften zu halten.

## **GARANTIE INTERNATIONALE**      **Version Française**

Pour connaître les procédures propres à la politique de garantie de votre pays, contactez votre revendeur ou distributeur International KICKER.

L'expression "carburant pour vivre plein pot" fait référence au dynamisme de la marque KICKER d'équipements audio pour véhicules et a pour but d'encourager nos clients à faire le maximum ("vivre plein pot") dans tous les aspects de leur vie. Les haut-parleurs et amplificateurs KICKER sont les meilleurs dans le domaine des équipements audio et représentent donc pour nos clients le "carburant pour vivre plein pot" dans l'aspect "installation audio de véhicule" de leur vie. Nous encourageons tous nos clients à respecter toutes les lois et réglementations locales relatives aux niveaux sonores acceptables à l'extérieur des véhicules.

P.O. Box 459

Stillwater, Oklahoma 74076

USA

(405) 624-8510

# **stillwaterdesigns**

Deutsche