

KICKER®

48PXA1000.5

Waterproof 4x100 Watt Class-D Full-Range Amplifier W/600 Watt Mono Amplifier; RoHS Compliant

Specifications

Electrical Parameters

Power (@14.4V, <1%THD+N)	4Ω Stereo	100W x 4
Power (@14.4V, <1%THD+N)	2Ω Stereo	150W x 4
Power (@14.4V, <1%THD+N)	4Ω Bridged	300W x 2
Power (@14.4V, <1%THD+N)	4Ω Mono	300W x 1
Power (@14.4V, <1%THD+N)	2Ω Mono	500W x 1
Power (@14.4V, <1%THD+N)	1Ω Mono	600W x 1
Dynamic Power (@14.4V, <10%THD+N)	4Ω Bridged + 1Ω Mono	1400W
Lowest Rated Impedance (Amp 1 & 2)		2Ω Stereo / 4Ω Bridged
Lowest Rated Impedance (Sub)		1Ω
Signal to Noise Ratio (CEA)	1W	>-75dB
Signal to Noise Ratio	Rated Power	>-95dB
Channel Separation (Rated Power) FR	1000Hz	>55dB
CMRR (Amp 1 & 2)	1000Hz	-40dB
CMRR (Sub)	50Hz	-40dB
Input Impedance		>20kΩ
Frequency Response (Amp 1 & 2)		10Hz - 20kHz
Frequency Response (Sub)		25Hz - 200Hz
Selectable HiPass Filter (Amp 1 & 2)	24dB / Octave BW	OFF, 80Hz, 120Hz
Selectable LoPass Filter (Sub)	24dB / Octave BW	60Hz, 80Hz, 100Hz, 120Hz
Fixed Subsonic Filter (Sub)	24dB / Octave BW	25Hz
KickEQ™ Selectable Bass Boost (Sub)	40Hz	0dB, 6dB
Standby Current (Remote Off)		<2mA
Idle Current (Remote On)		<3A
Current Draw (Rated Power)		<150A
Remote Gain Attenuation (Sub)		-26dB - 0dB
Low Level Input Sensitivity		125mV - 5V
High Level Input Sensitivity		1V - 40V
Under Voltage Protection		8.5V (warning at 10.5V)
Over Voltage Protection		16V

What's in the box?

48PXA1000.5

PXA1000.5 Customer Information Card

Stainless Steel Mounting Hardware

2 DC Power Wire Couplers

Physical Materials

Heat Sink	Powder Coated Die Cast Aluminum
Bottom Panel	Anodized Stamped Aluminum
Signal Wire Pigtail	3x Twisted Pair Conductor RCA
Power Wire Pigtail	8AWG OFC Power and Ground/16AWG OFC remote
Subwoofer Speaker Wire Pigtail	12AWG OFC Sub
Full Range Speaker Wire Pigtail	16AWG OFC Full Range (CEA Color Coding Standard)



Features

- IP66/IP67 Certified Waterproof Amplifier Design
- Inline Power and Ground Couplers that need no soldering or crimping
- Intelligent Thermal Rollback for All-day play time
- Subsonic Filter for subwoofer protection
- KickEQ™ Bass Boost (Sub Channel only)
- Compact Footprint - Ideal for space challenged vehicles
- Remote Output Level Control with CXARC (sold separately)

Unit Dimensions

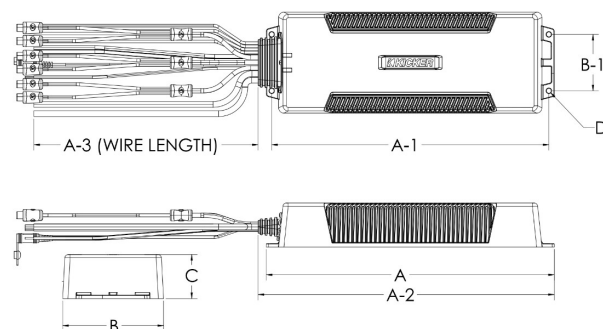

A - Overall Length	12-7/8"	327.5mm
A-1 - Mounting Holes Location - Length	12-7/16"	315.2mm
A-2 - Overall Length with Bulkhead	13-1/4"	336.8mm
A-3 - Wire Length	9-13/16"	250.0mm
B - Overall Width	4-1/2"	114.7mm
B-1 - Mounting Holes Location - Width	2-1/2"	64.0mm
C - Overall Height	1-15/16"	50.0mm
D - Mounting Hole Diameter	7/32"	5.5mm

Technical Graph Data

AMP1 and AMP2 - THD+N vs. Power (W) @14.4VDC

THD+N Ratio (%) vs. Power (W)

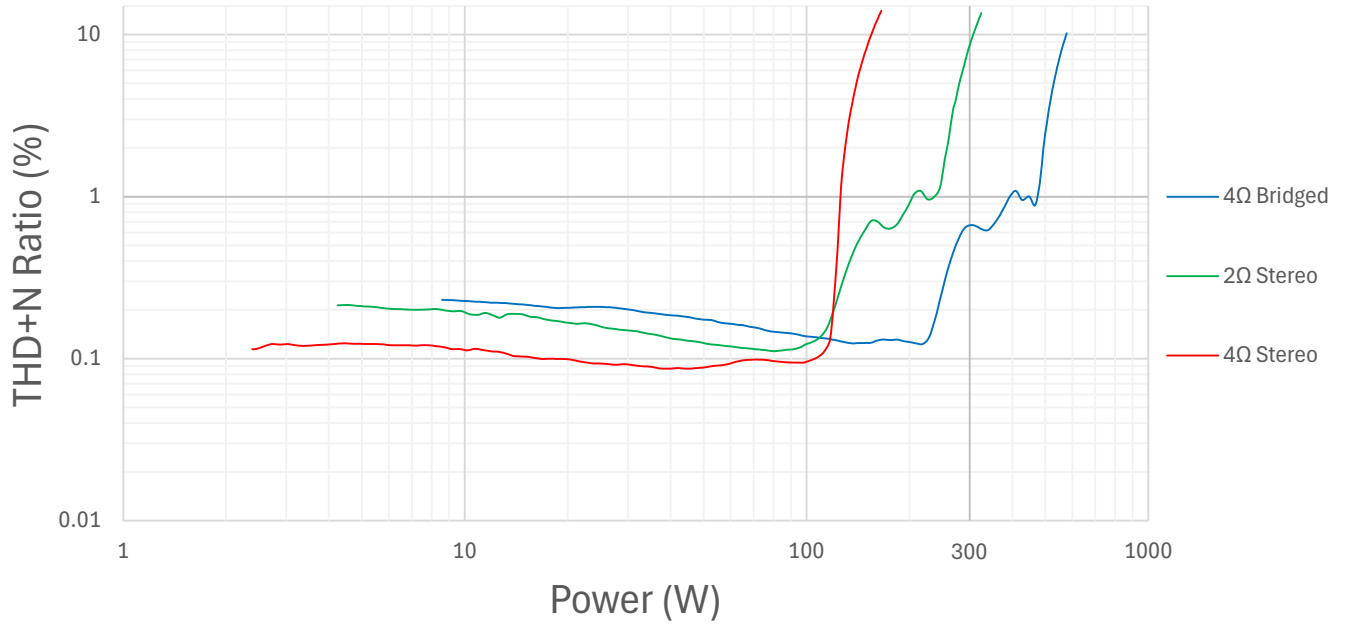

SUB - THD+N vs. Power (W) @14.4VDC

THD+N Ratio (%) vs. Power (W)

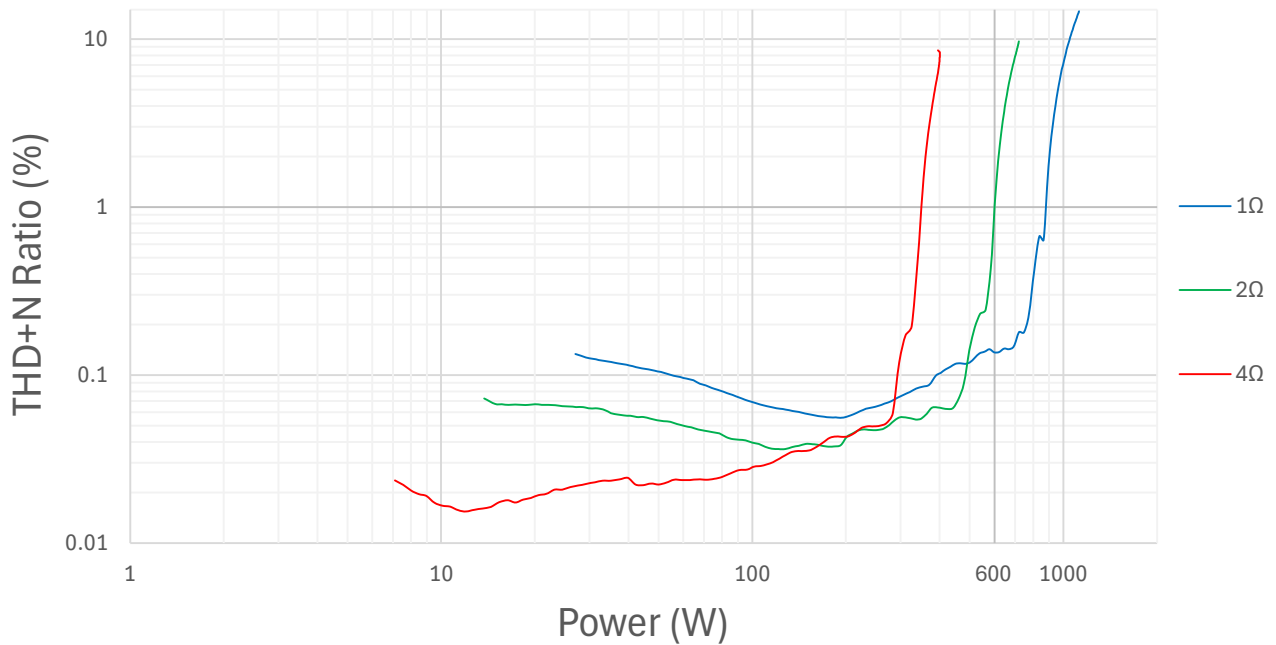

AMP1 and AMP2 - Power Bandwidth (4Ω) @14.4VDC

Power Bandwidth, re: Rated Power (100W @ 4Ω)

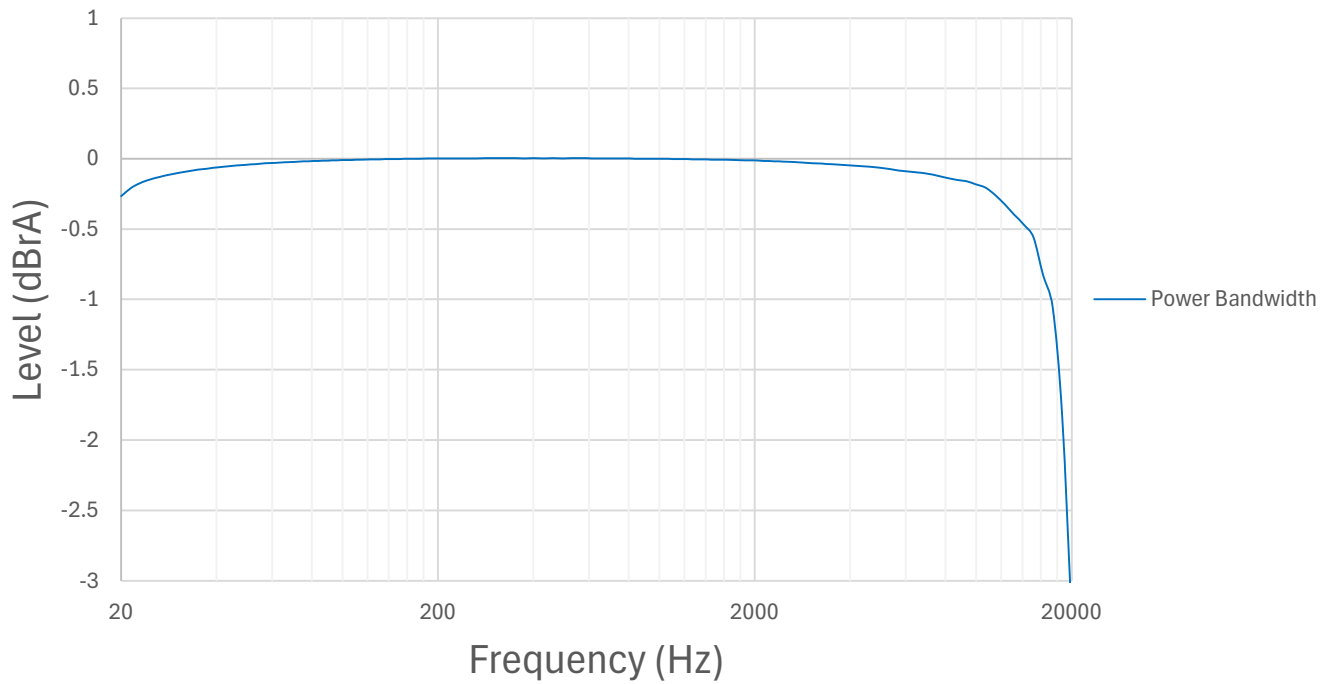

SUB - Power Bandwidth (4Ω) @14.4VDC

Power Bandwidth, re: Rated Power (300W @ 4Ω)

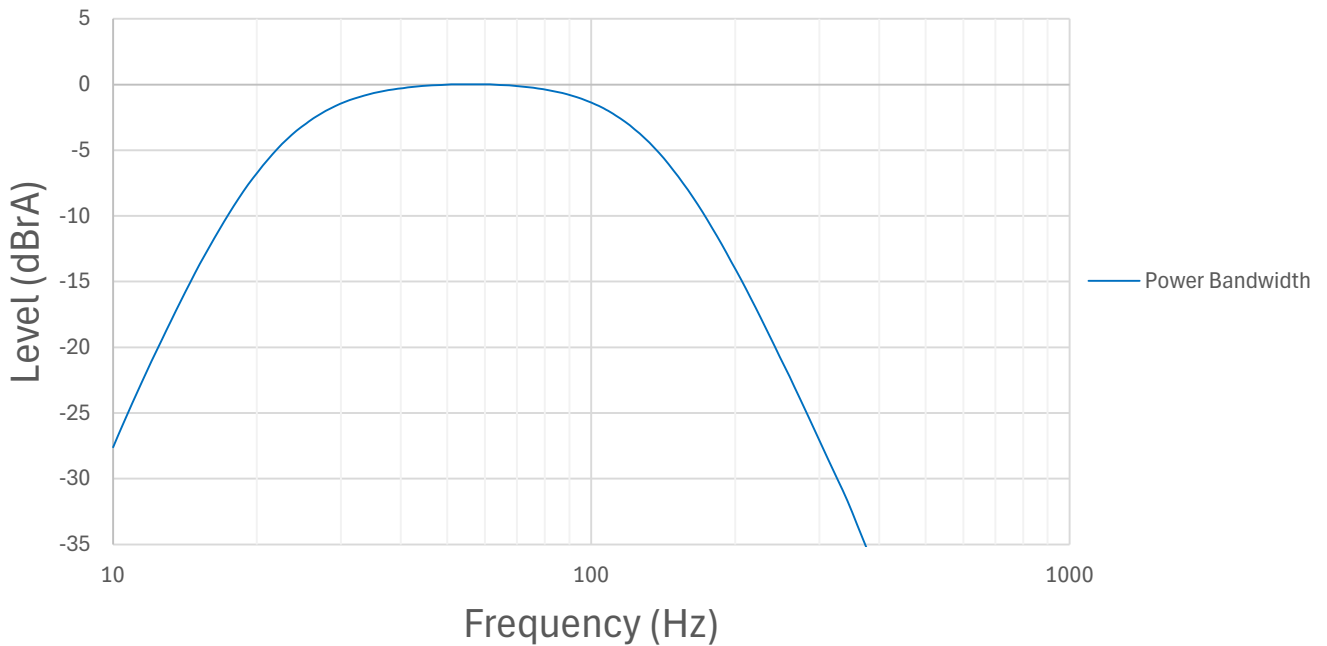

AMP1 and AMP2 - FFT

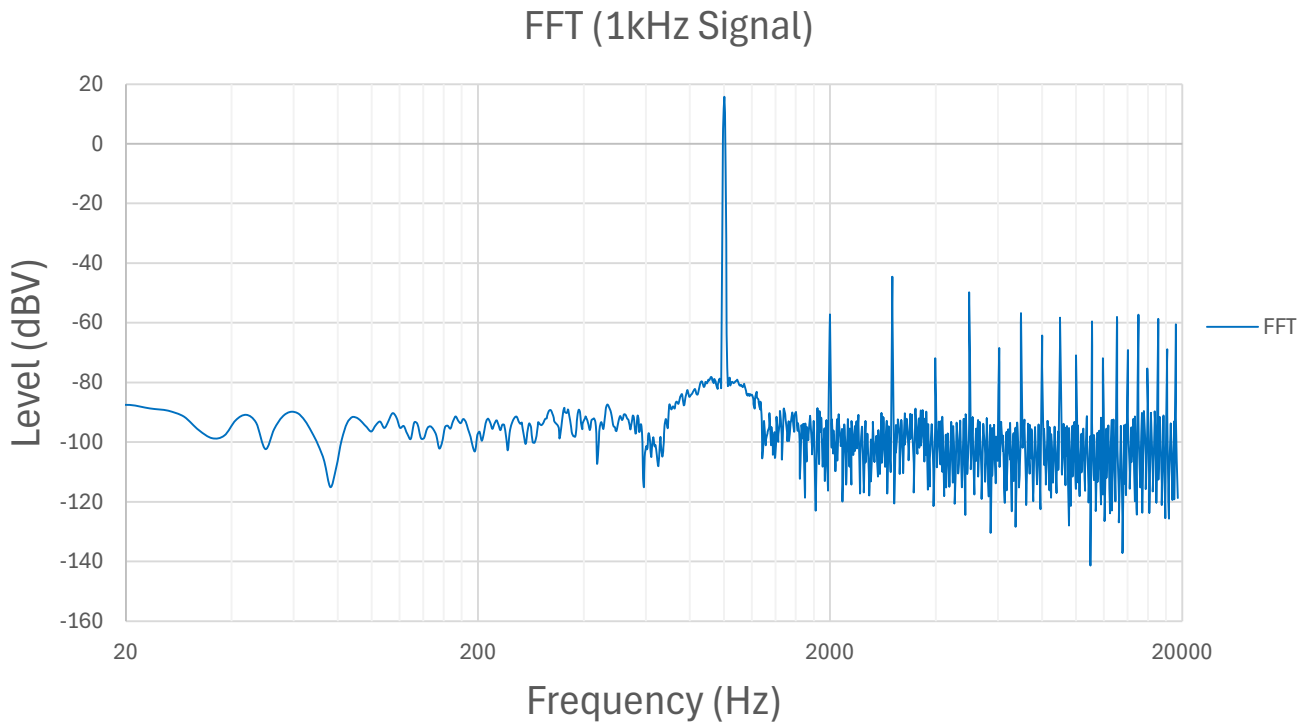

SUB - FFT

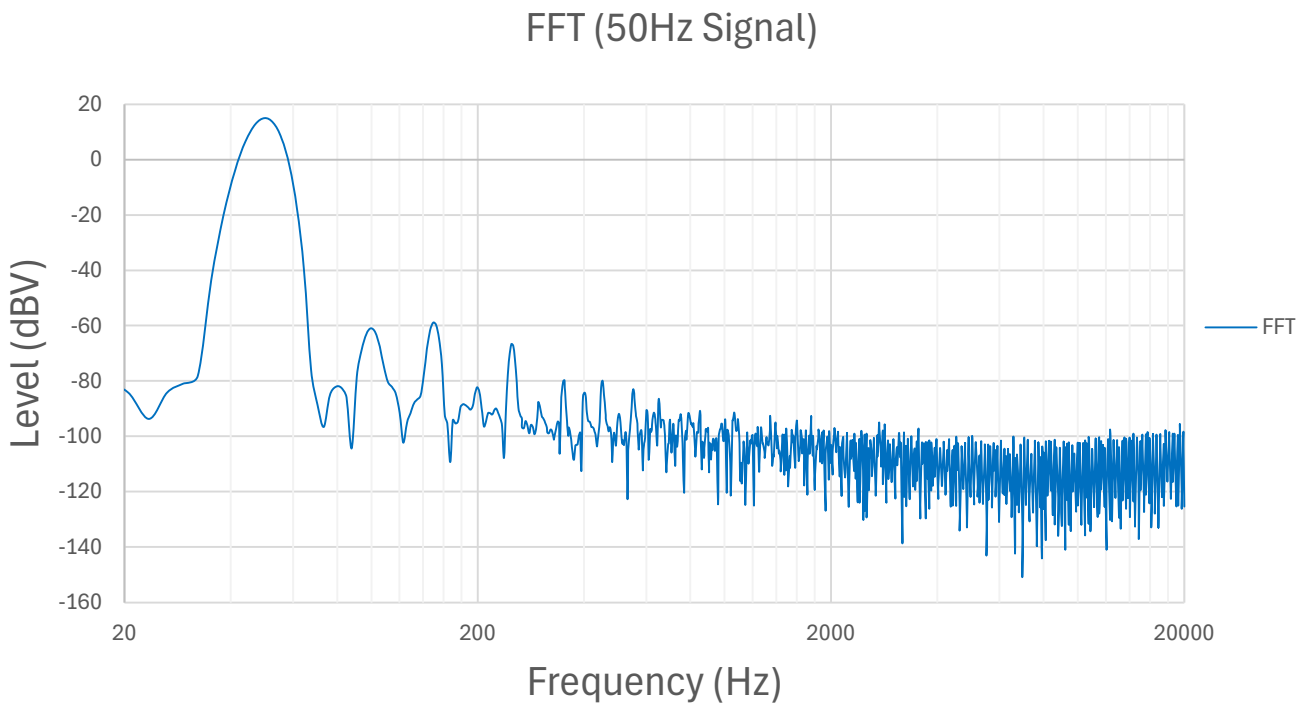

AMP1 and AMP2 Crossover Frequency Response

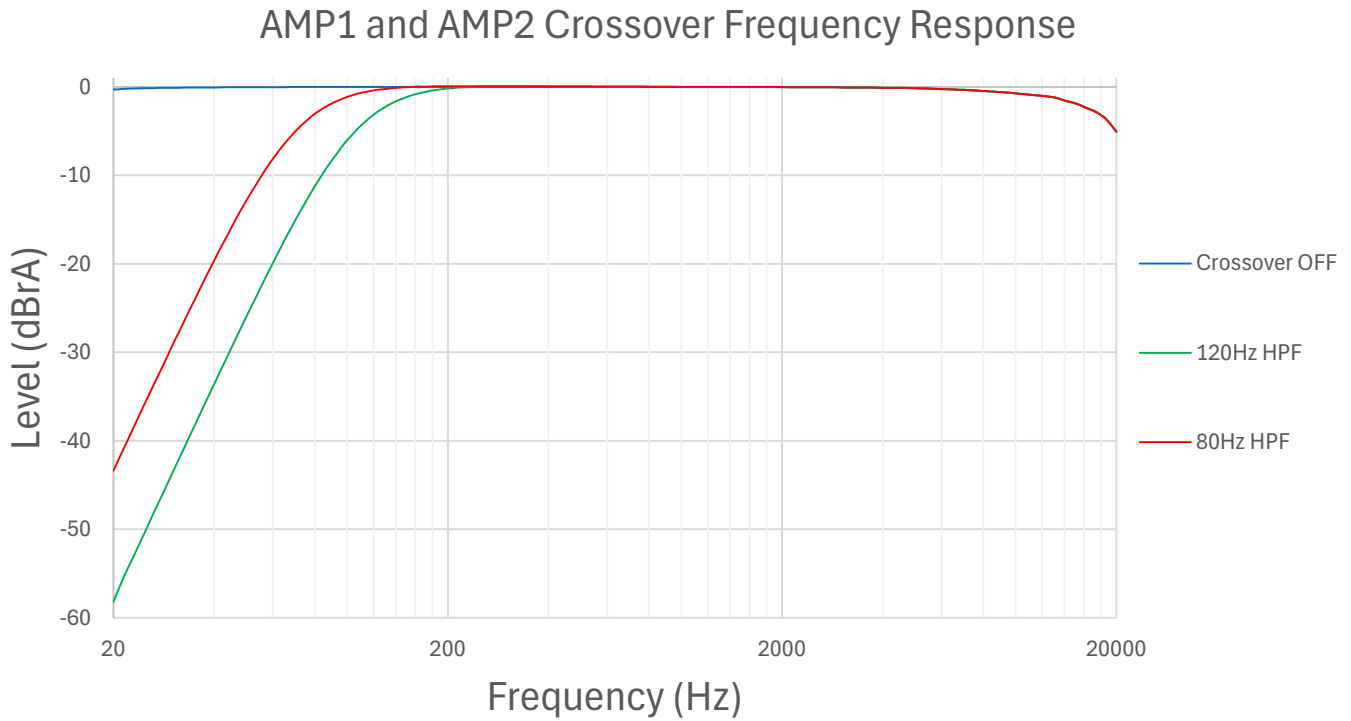

SUB Crossover Frequency Response

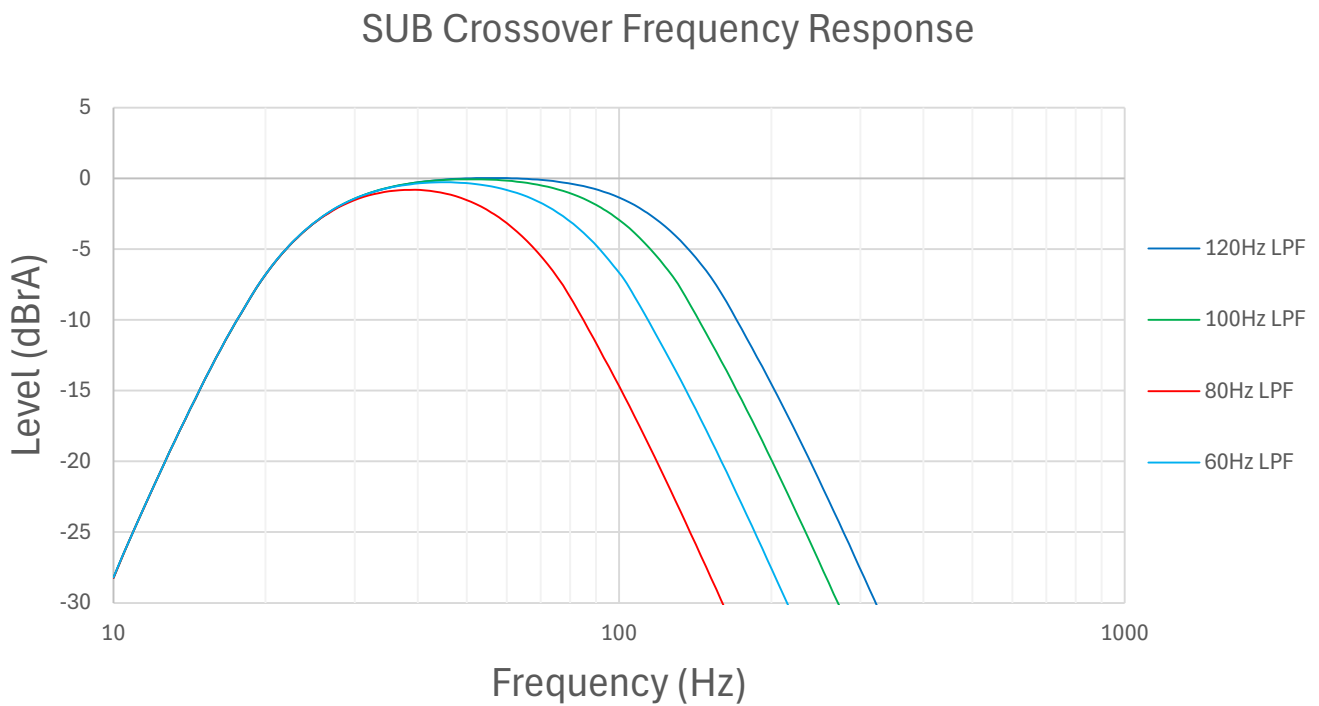

KickEQ™

